



We put you first.
And keep you ahead.

Schilling Robotics

ATLAS Slave Arm
Rate-Controlled,
6.5 Km Submersible



Document No. 011-8242

Models:

199-0292-1

199-0292-2

199-0292-3

199-0292-4

199-0322-1

199-0322-2

Copyright © 2012 by Schilling Robotics, LLC. All rights reserved.

Schilling Robotics, the FMC Technologies logo, and their frameworks are trademarks and service trademark applications of FMC Technologies. No part of this document may be reproduced or used in any form without the express written permission of FMC Technologies. Descriptions and specifications are subject to change without notice.

FMC Technologies Schilling Robotics

260 Cousteau Place, Suite 200, Davis, CA 95618 • Ph: (530) 753-6718 • Fax: (530) 753-8092

Sales Schilling.Sales@fmcti.com • Tech Support Schilling.TS@fmcti.com
Customer Service Schilling.CS@fmcti.com • Web Site <http://www.schilling.com>

TECHNICAL MANUAL REVISION LOG		
Product: Atlas, 199-0292-1, -2, -3, -4, 199-0322-1, -2		
Technical Manual: 011-8242		
Description	Date	Rev.
Cloned from 011-8228 for Gutenberg.	July, 2012	A

Table of Contents

Table of Contents	3
Specifications	7
General Description	7
Slave Arm Specifications	7
Slave Arm Functions	8
Hydraulic Specifications	8
Environmental Specifications	9
Slave Arm Features & Dimensions	9
Mounting Dimensions	9
Stow Dimensions	11
Slave Arm Range of Motion	12
Installation	13
Location	13
Mounting	13
Hydraulic Connections	13
First Startup Adjustments	14
Operation	16
Pre-Start Checks	16
Troubleshooting	17
Jaw is Noisy When Operated	18
Inspection	18
Jaw Low Grip Force	19
Inspection	19
Jaw Failure T-bar Plates or Jaw Bolts	20
Inspection	20
Linear Actuator Low Force	21
Inspection	21
Linear Actuator Slow Movement	22
Inspection	22
Free Play In Joints	23
Inspection	23
Slave Arm Reduced Range of Motion	24
Inspection	24
Slave Arm Jerky Operation	25

Inspection	25
Slave Arm Hose Failure	26
Inspection	26
Wrist Stalling	27
Inspection	27
Low Wrist Torque	28
Inspection	28
Wrist Noise when Rotating	29
Inspection	29
Periodic Maintenance	30
Service Instructions	31
Noseblock Rebuild	32
Disassembly	32
Reassembly	32
Wrist Driveshaft Replacement	34
Removal	34
Installation	34
Wrist Motor Rebuild	37
Disassembly	37
Reassembly	38
Linear Actuator Remove and Replace	42
Disassembly	42
Reassembly	44
Atlas Yaw Actuator	45
Removal	45
Changing Manipulator Direction From Left to Right	47
Disassembly	47
Pitch Actuator Replacement	51
Removal	51
Installation	52
Atlas Forearm Segment	53
Removal	53
Reassembly	53
Atlas Upper Arm Segment	55
Removal	55
Azimuth Block Remove and Replace	56

Disassembly	56
Reassembly	57
Atlas Base Remove and Replace	59
Disassembly	59
Reassembly	61
Atlas Typical Bushing Replacement	63
Part # 010-1457 -Bushing Replacement Tool	63
Bushing Removal	63
Bushing Installation	63
Drawings, Schematics, Part Lists	65
Spares Kit 008-0506	65
Spares Kit 008-0216 (Item 1 in Spares Kit 008-0506)	66
Spares Kit 008-0509 (Item 3 in Spares Kit 008-0506)	66
Spares Kit 008-0510 (Item 4 in Spares Kit 008-0506)	67
Spares Kit 008-0096 (Item 6 in Spares Kit 008-0506)	67
Tool Kit 010-1386	68
Atlas Hydraulic Schematic 025-0132	69
Hose Routing, Left Hand Configuration	70
Hose Routing, Right Hand Configuration	71
Linear Actuators	72
Anodes and Bump Stops	73
Bushings and Inserts	74
Sensor Covers	75
Pins and Spacers	76
Major Structures	77
Linear Actuators	78
Wrist, 101-3786	79
Jaw, 101-3299	80
Jaws, 101-3569	81
Noseblock, 101-3853	82

Specifications

General Description

General	
Item	Specification
Control method	Rate control
Input device	Optional rate hand controller
Number of functions	6 plus grip
Materials of construction	6061-T6 aluminum, stainless steel, titanium

Slave Arm Specifications

All specifications are based on the standard system configuration using Shell Tellus Oil 32 hydraulic fluid, input pressure of 207 bar (3,000 psi), and available flow of 19 lpm (5 gpm).

Slave Arm Specifications	
Item	Specification
Depth rating	6,500 msw (21,327 fsw)
Maximum reach (from azimuth pivot to standard gripper T-bar slot)	1,664 mm (65.5-inch)
Weight in air	73 kg (160 lb)
Weight in seawater	50 kg (109 lb)
Lift at full extension, nominal, in stowed position	250 kg (550 lb)
Maximum lift, nominal	500 kg (1,000 lb)
Maximum gripper opening (standard gripper), nominal	198 mm (7.8 inch)
Grip force, nominal	4,448 N (1,000 lbf)
Grip force, maximum	xx?
Wrist torque, nominal	205 Nm (150 ft/lb)
Wrist torque, maximum	xx?
Wrist rotate, nominal	360°, 6-35 rpm

Slave Arm Functions

Slave Arm Functions		
Actuator Function	Type	Nominal Mechanical Range
Azimuth	Linear	120°
Shoulder pitch	Linear	135°
Elbow pitch	Linear	135°
Wrist pitch	Linear	120°
Wrist yaw	Linear	120°
Wrist rotate	Gerotor	360°
Gripper	Linear	198 mm (7.8-inch)

Hydraulic Specifications

 Contact the factory about operation at other pressures and flow rates.

Hydraulic Specifications	
Item	Specification
Approved Fluids	
Hydraulic oil	All common mineral, glycol, & environmentally friendly fluids
Requirements	
Viscosity	10 cSt to 200 cSt
Available flow	5.7 - 19.0 lpm (1.5 - 5.0 gpm)
Pressure	103 bar (1,500 psi) minimum to 207 bar (3,000 psi) maximum; slave arm performance is reduced at less than 207 bar (3,000 psi)
Hydraulic fluid temperature, maximum	60 °C (140 °F)
Oil cleanliness	less than or equal to 17/14/11, per ISO 4406-1999
Customer-Supplied Mating Fittings Required	
Hose fittings	-4 JIC female, 1/4 inch

Environmental Specifications

Environmental Specifications	
Item	Specification
Operating temperature	-2 °C to +54 °C (+28 °F to +130 °F)
Storage temperature	-15 °C to +71 °C (+5 °F to +160 °F)
Humidity	0% to 100% condensing

Slave Arm Features & Dimensions

Models 199-0322-1 and 199-0322-2 do not have the base-mounted hose manifold.

Mounting Dimensions

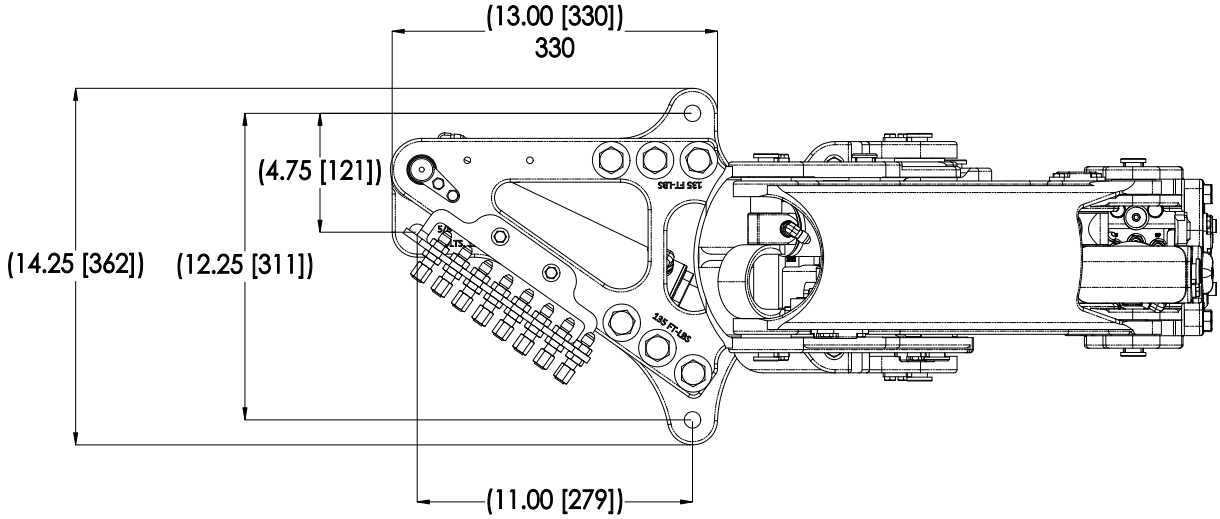
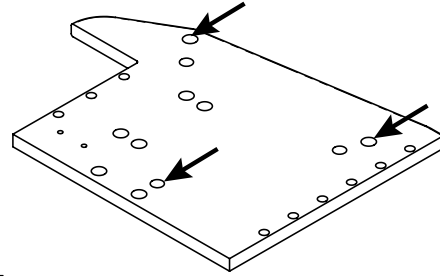
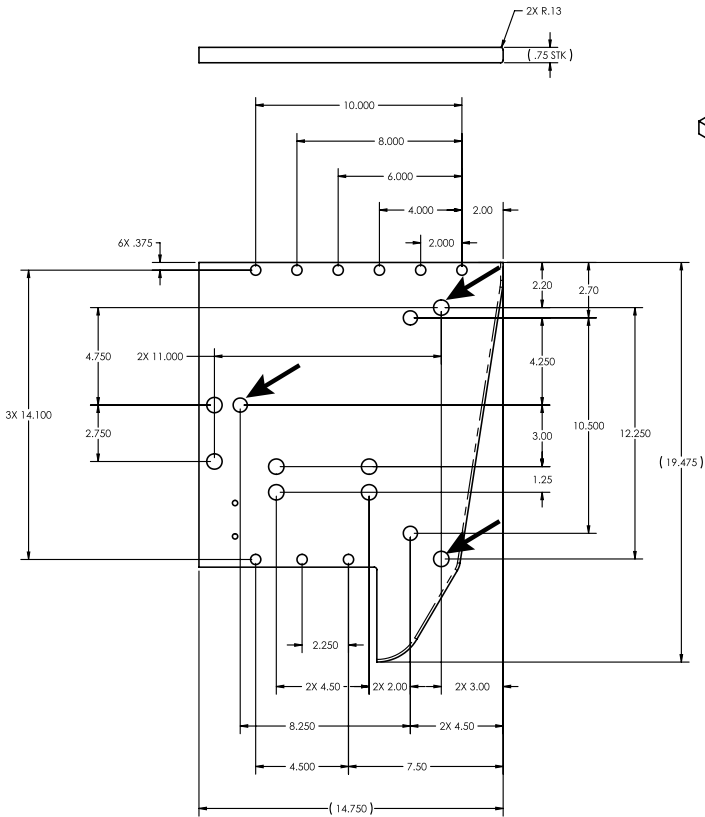

Figure: Mounting dimensions



Mounting holes (shown by arrows),
0.656-inch diameter

Figure: Mounting holes

Stow Dimensions

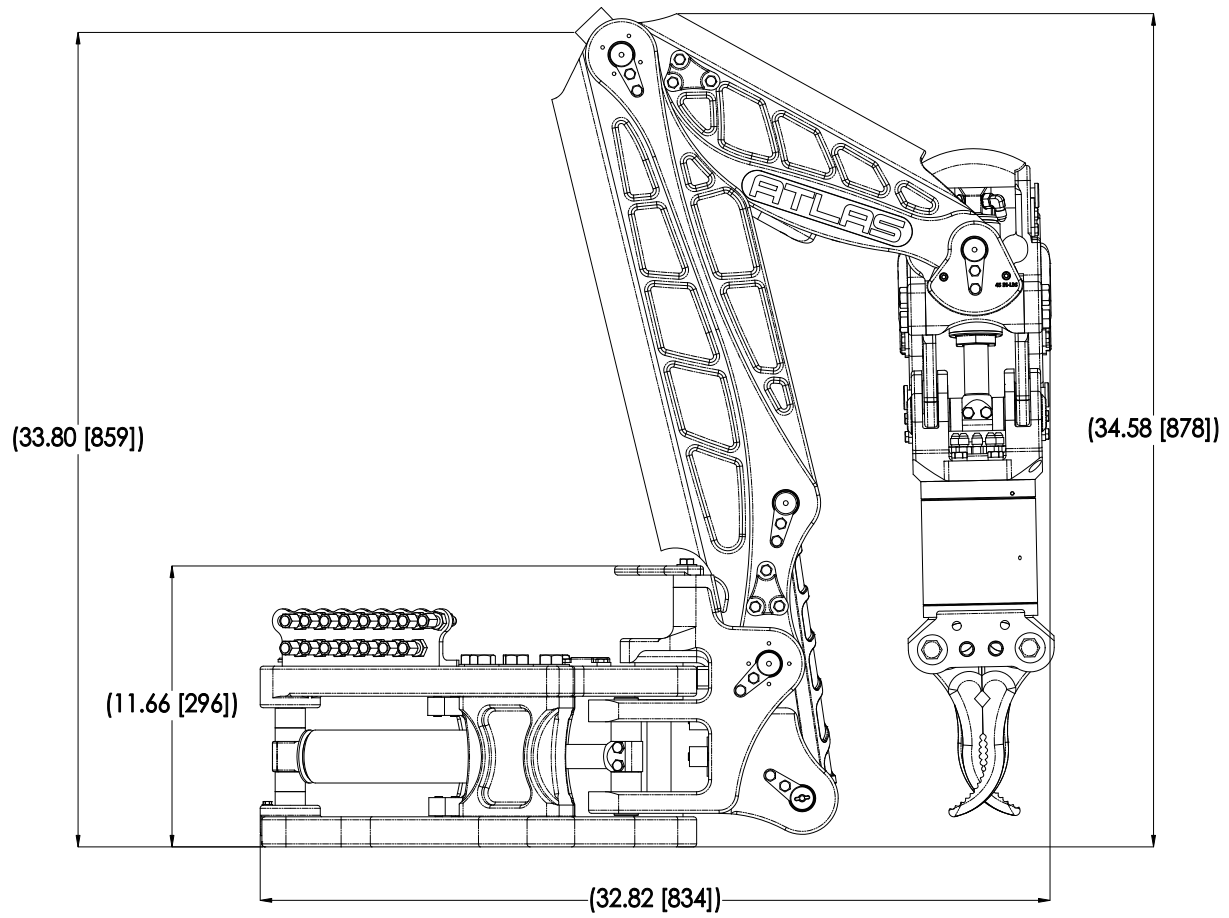

Figure: Stow dimensions

Slave Arm Range of Motion

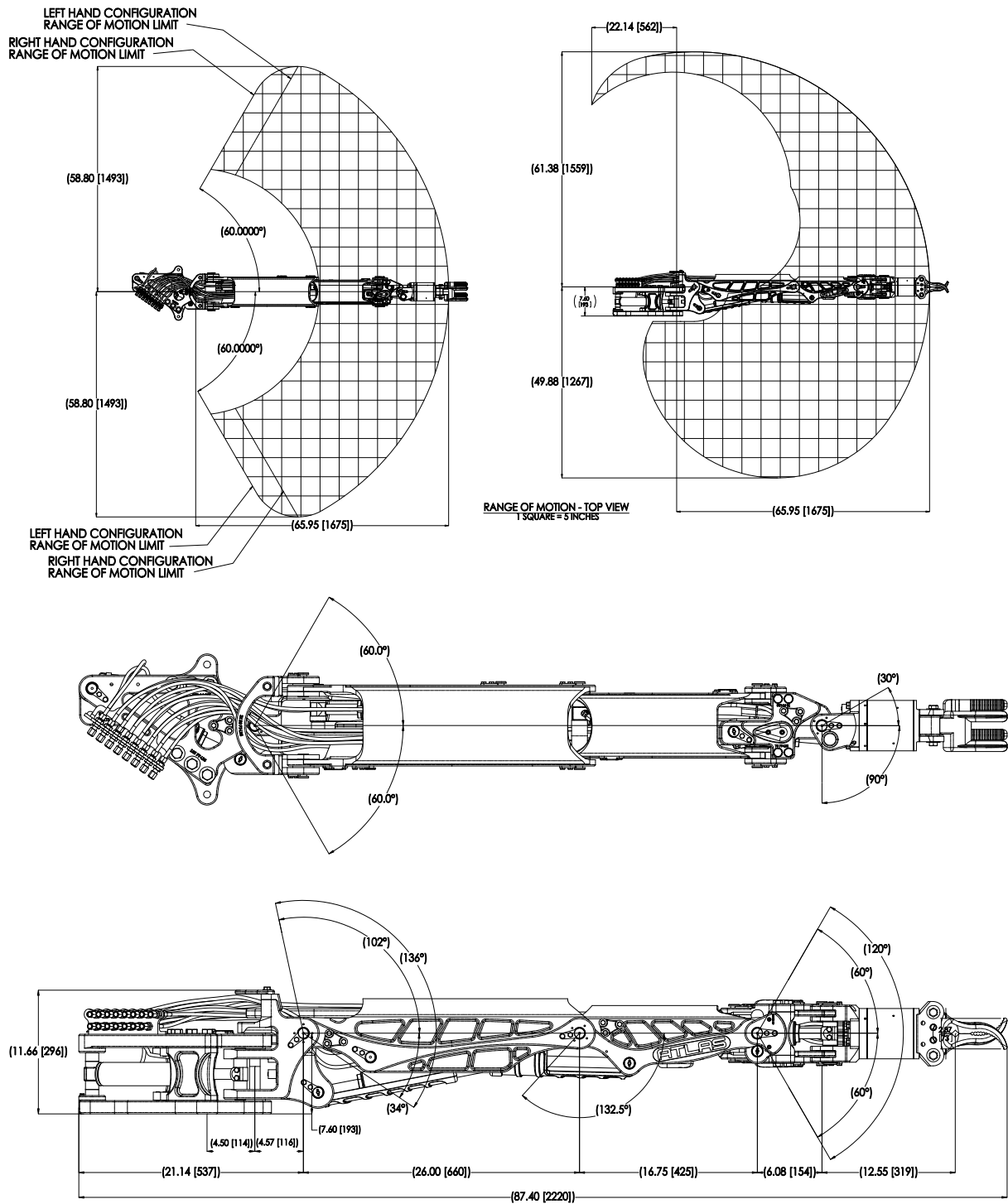

Figure: Range-of-motion dimensions Mounting

Installation

Location

The ideal mounting location maximizes the slave arm's range of motion in the work area, while allowing the slave arm to be stowed far enough within the vehicle's protective bumpers to prevent collision damage during launch and recovery.

Mounting

Install the Atlas with three 15 mm (5/8 inch) fasteners (not supplied) to a suitable flat mounting surface (minimum 17 mm/0.67 inch thick aluminum). Use fasteners that can be locked (nylock or safety-wired hardware, standard hardware and Loctite, etc.).

- The fasteners can be either threaded into the mounting base (minimum thickness to equal one-bolt diameter), or pass through if there is access to the underside of the mounting plate.
- Torque the bolts to 99 Nm (135 ft/lb).

Hydraulic Connections

1. Connect two user-supplied hoses from the hydraulic control manifold to each of the 7 functions on the Atlas manifold. The hoses are marked 0A 0B, 1A 1B, etc. (see Table 1). Connect the wrist motor case drain to the same hydraulic reservoir as the controlling manifold.

Hydraulic Connections			
Slave Arm Function	Hose Code	Actuator Movement	Joint Movement
Azimuth yaw	0A	Extend	Left
	0B	Retract	Right
Shoulder pitch	1A	Extend	Up
	1B	Retract	Down
Elbow pitch	2A	Extend	Up
	2B	Retract	Down
Wrist pitch	3A	Extend	Up
	3B	Retract	Down

Hydraulic Connections (continued)			
Slave Arm Function	Hose Code	Actuator Movement	Joint Movement
Wrist yaw	4A	Extend	Left (left-hand Atlas models) Right (right-hand Atlas models)
	4B	Retract	Right (left-hand Atlas models) Left (right-hand Atlas models)
Wrist rotate (referenced from behind)	5A	Rotate CCW	Continuous CCW
	5B	Rotate CW	Continuous CW
Jaw	6A	Extend	Open
	6B	Retract	Close
Wrist drain/return	C	N/A	N/A

2. Install over-pressure relief valves for all functions on the hydraulic manifold controlling the slave arm. Adjust the cracking pressure as shown in the “Hydraulic Schematic, 025-0132” on page 31.

 *ALWAYS install the relief valve between the restrictor valve (if used) and the actuator to prevent over-pressurization should a joint be forced such as by a collision.*

3. When operated with On/Off-type valves (solenoid or proportional valves being driven On/Off only), install adjustable flow-restrictors to limit the maximum velocity of the joint function. For smooth operation, the adjustable restrictors should be installed on the ports that act as the return circuits. For example, if you pressurize port A to cause a joint to move, restrict Port B to limit the speed of the joint.

 *The relief and restrictor valve arrangement is also shown on the slave arm hydraulic schematic 025-0132.*

Lock valves (pilot-operated check valves) should be used on most functions to keep them from dropping due to control valve leakage. Do not install a lock valve on the jaw. (A lock valve is not effective on the wrist due to internal leakage.)

First Startup Adjustments

1. Check that the mounting fasteners are correctly torqued and locked.
2. Check that all hydraulic connections are tightened.
3. Set all adjustable restrictors to the lowest flow setting.

4. Have all personnel move outside the operational range of the slave arm.
5. Turn on the hydraulic supply and activate one function at a time. Open the restrictor to obtain the desired joint velocity.
6. Operate all joints through the full range of motion to purge all air from the actuators. It may be necessary to crack (open slightly) the hydraulic fittings at the base manifold and actuate the functions to purge remaining air if the connection hoses to the manifold are long or large in diameter.
7. A “soft” or “spongy” feel when pushing on the arm indicates that air remains in the actuators or hoses. Continue to bleed air until each joint becomes rigid when not in operation.

 *It is not necessary to bleed air from the wrist motor.*

Operation

In a typical ROV installation, Atlas hydraulic functions are controlled by a user-supplied valve pack fitted with hydraulic solenoid valves and/or proportional valves. The operator controls the valve pack with a set of 3-position, center-off, momentary switches on the pilots console. The Rate Hand Controller (005-2909) can also be used in place of a standard switch set. Since the valve pack and controls are not part of the Atlas system, consult their OEM documentation for more information.

When used on Schilling Robotics ROV systems, Atlas slave arm functions may be controlled through a rate hand controller or control puck, switch set, or the user-interface touch screens. See the “System Software & Controls” volume of your ROV system technical manual for details.

Pre-Start Checks

Before operating the slave arm, check the following:

- All hoses, fasteners, and fittings are connected and secure.
- Air has been purged from the hydraulic system if any lines or components have been disconnected for maintenance or repair.
- No personnel or objects are within the slave arm’s range of motion.



WARNING! Before turning on hydraulic power, move all personnel and equipment outside the slave arm’s range of motion.

Troubleshooting

Jaw is Noisy When Operated	18
Jaw Low Grip Force	19
Jaw Failure T-bar Plates or Jaw Bolts	20
Linear Actuator Low Force	21
Linear Actuator Slow Movement	22
Free Play In Joints	23
Slave Arm Reduced Range of Motion	24
Slave Arm Jerky Operation	25
Slave Arm Hose Failure	26
Wrist Stalling	27
Low Wrist Torque	28
Wrist Noise when Rotating	29
Periodic Maintenance	30

Jaw is Noisy When Operated

Inspection

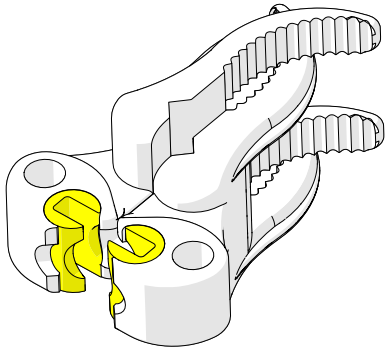

1. Is the Jaw Actuation Bearing clean and lubricated?

YES - Go to step 2.

NO - Clean and lubricate the bearing. [xxLink to info on recommended lubricants?](#)

 *Use minimal lubricant to prevent the accumulation of grit on rotating surfaces.*

2. Is the jaw actuation bearing excessively worn?

YES - Replace the jaw actuation bearing.

NO - Go to step 3.

3. Does the actuating bearing fit snugly in the jaw rocker?

YES - Go to step 4.

NO - Adjust the seating of the actuating bearing.

4. Is the jaw actuation bearing loose?

YES - Replace the Rocker.

NO - Check torque on jaw fittings.

Jaw Low Grip Force

Inspection

1. Is the hydraulic pressure correctly set?

YES - Go to step 2.

NO - Adjust the hydraulic pressure.

2. Is the jaw actuating bearing clean and lubricated?

YES - Go to step 3.

NO - Clean and lubricate the jaw actuating bearing.

 *NOTE: Use minimal amount of lubricant to prevent accumulation of grit on the rotating surfaces.*

3. Is the relief valve correctly set?

YES - Go to step 4.

NO - If set too low, correct the setting.

4. Has the jaw piston seal been inspected?

YES - Go to step 5.

NO - Remove and inspect the jaw piston seal. Replace if necessary.

5. Has the jaw slipring seals been inspected?

YES - Go to step 6.

NO - Remove and inspect the jaw slipring seals. Replace if necessary.

6. Has the wrist drilled bolt O-rings and seals been inspected?

NO - Remove and inspect the wrist drilled bolt O-rings and seals. Replace if necessary.

Jaw Failure T-bar Plates or Jaw Bolts

Inspection



WARNING! *Avoid flying the vehicle with the arm outstretched and jaw fully opened.*

1. Is the jaw rocker spread open?
YES - Replace the rocker actuation bearing and the T-bar.
NO - Go to step 2.
2. Is the relief valve correctly set?
YES - Go to step 3.
NO - If set too low, correct the setting.
3. Is the jaw bolt torqued to the specified value?
NO - Torque to specified value.

Linear Actuator Low Force

Inspection

1. Is the hydraulic pressure adequate?
 - YES** - Go to step 2.
 - NO** - Diagnose hydraulic system.
2. Are the relief valves adjusted properly?
 - YES** - Go to step 3.
 - NO** - Adjust or replace the relief valves as necessary.
3. Is there heat or a hissing sound coming from the piston seal?
 - YES** - Replace piston seal.
 - NO** - Replace the actuator piston seal.

Linear Actuator Slow Movement

Inspection

1. Is the hydraulic pressure adequate?
 - YES** - Go to step 2.
 - NO** - Make sure hose connections are tight.
2. Are the flow restrictors adjusted correctly?
 - YES** - Go to step 3.
 - NO** - Adjust or replace the flow restrictors as necessary.
3. Are there any pinched hoses?
 - YES** - Adjust routing of hoses to ensure appropriate movement without pinching.
 - NO** - Go to step 4.
4. Is there hissing or excessive heat coming from the actuator?
 - YES** - Replace actuator seal.

Free Play In Joints

Inspection

1. Do bearings in the joints need replacing?

YES - Replace bearings

NO - Go to step 2.

2. Do the pins show any excessive wear?

YES - Replace the joint pin.

NO - Go to step 3.

3. Do any of the pin holes have excessive "egg" shaped wear?

YES - Replace arm segment.

Slave Arm Reduced Range of Motion

Inspection

1. Is the arm structure straight?

YES - Go to step 2.

NO - Send in manipulator arm for repair.

2. Are joint hard stops correctly installed?

YES - Go to step 3.

NO - Inspect or replace the hard stops.

3. Are joint pins straight?

YES - Go to step 4.

NO - Replace joint bent pins.

4. Does the manipulator have foreign debris in joints or cavities?

YES - Clean debris from manipulator.

Slave Arm Jerky Operation

Inspection

1. Are the restrictors and relief valves adjusted properly?

YES - Go to step 2.

NO - Adjust or replace the relief valves as necessary.

2. Does the manipulator show signs of a bent actuator or arm structure?

YES - Replace actuator or bent structural pieces.

Slave Arm Hose Failure

Inspection

1. Is the hose properly routed through manipulator?

YES - Go to step 2.

NO - Re-route hose so that it is free from pinch points and binding.

2. Are the relief valves adjusted properly?

NO - Adjust or replace the relief valves as necessary.

Wrist Stalling

Inspection

Are the flow restrictors adjusted properly?

YES - Go to next step.

NO - Adjust flow restrictors.

Is the relief valve adjusted properly?

YES - Replace gerotor assembly if unable to hold minimum 8 RPM.

NO - Adjust relief valve.

Low Wrist Torque

Inspection

Is the arm being supplied with at least 3,000 PSI of hydraulic pressure?

YES - Go to next step.

NO - Adjust hydraulic pressure.

Are the hoses all connected properly?

YES - Go to next step.

NO - Secure all hose connections.

Are the relief valves set properly?

YES - Go to next step.

NO - Raise the valves to the proper setting.

Are the restrictors set too low?

YES - Increase flow from restrictors.

NO - Replace gerotor assembly.

Wrist Noise when Rotating

Inspection

It is not unusual for a "clattering" or gear sound to come from the wrist motor during operation. If performance is adequate, no action is required.

Periodic Maintenance

Periodic Maintenance Table	
Daily Checks	
<input type="checkbox"/>	Check for loose or missing fasteners.
<input type="checkbox"/>	Check hoses for evidence of kinking or abrasion.
<input type="checkbox"/>	Check hose fittings for leaks.
<input type="checkbox"/>	Check actuator rods for damage and check actuators for signs of hydraulic leaks.
<input type="checkbox"/>	Thoroughly wash the slave arm exterior with fresh water. Remove any entrapped debris.
Weekly Checks	
<input type="checkbox"/>	Perform the daily checks.
<input type="checkbox"/>	Check anodes and replace when 1/3 or less remains.
<input type="checkbox"/>	Push on the arm and check for excessive free play which may indicate worn bearings or pins.
<input type="checkbox"/>	Torque all external fasteners to specified values.
<input type="checkbox"/>	Check jaw actuation bearings and T-bar plate for damage.
Monthly Checks	
<input type="checkbox"/>	Perform the daily and weekly checks.
<input type="checkbox"/>	Check all hydraulic fittings for tightness.
<input type="checkbox"/>	Remove external fasteners individually, reapply anti-seize compound, and torque to specified values.
Every 6 Months	
<input type="checkbox"/>	Replace all arm segment bushings.
<input type="checkbox"/>	Inspect pivot pins for wear. Replace if wear is more than 0.005 inch.
<input type="checkbox"/>	Replace jaw actuation bearings.
Every 2 Years	
<input type="checkbox"/>	Replace seals and bearings in all linear actuators.
<input type="checkbox"/>	Replace seals and bearings in jaw actuator.
<input type="checkbox"/>	Replace wrist roller bearings, seals, bushings, and O-rings.
<input type="checkbox"/>	Replace wrist gerotor.

Service Instructions

- Noseblock Rebuild 32
- Wrist Driveshaft Replacement 34
- Wrist Motor Rebuild 37
- Linear Actuator Remove and Replace 42
- Atlas Yaw Actuator 45
- Changing Manipulator Direction From Left to Right 47
- Pitch Actuator Replacement 51
- Atlas Forearm Segment 53
- Atlas Upper Arm Segment 55
- Azimuth Block Remove and Replace 56
- Atlas Base Remove and Replace 59
- Atlas Typical Bushing Replacement 63

Noseblock Rebuild

Disassembly

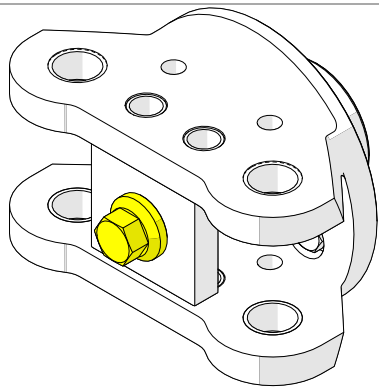

1. Open the jaws and loosen the jaw rod bolt. Do not remove the bolt.

 *Use a lever in the opened jaws to counteract the torque.*

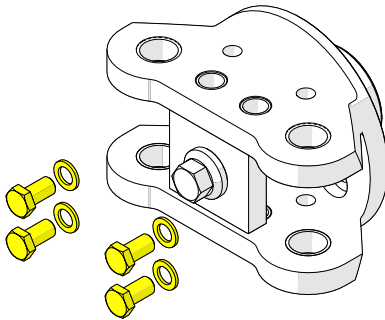

2. Remove the jaws.
3. Remove the 4 bolts that attach the noseblock to the wrist, then remove the noseblock.

4. Remove the jaw rod bolt and disassemble the remaining parts.
5. Remove the seals with a razor knife if they need to be replaced.

 *Use care to not scratch the metal surfaces.*

Reassembly

1. Install O-rings and bearings into the noseblock as shown.
2. Lubricate all seals and O-rings before assembly.
3. Use a sizing tool to stretch the jaw piston seal. Use resizing tools for the noseblock and piston seal.

⚠ The bearing must be installed on the piston before the piston seal to support the resizing tool. Failure to do so may damage to the resizing tool.

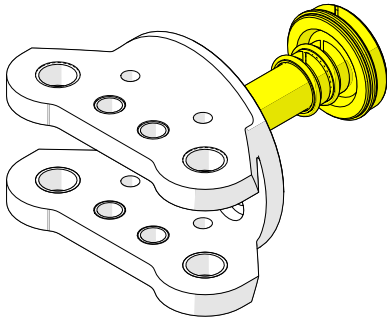

4. Use the resizing tool on the end of the jaw rod to install the rod into the noseblock.

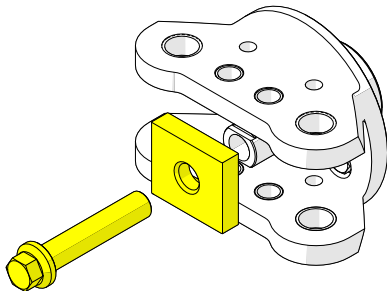

5. Lubricate the jaw bolt with anti-seize. Thread the bolt through the T-bar plate and into the jaw piston. Do not yet tighten the jaw rod bolt.

6. Install the noseblock on the wrist with 4 bolts.
7. Torque bolts to 73 lbf-ft (99 Nm)
8. Install the jaws.
9. Tighten the jaw rod bolt.
10. Torque jaw rod bolt to 160 lbf-ft (217 Nm)

Wrist Driveshaft Replacement

Removal

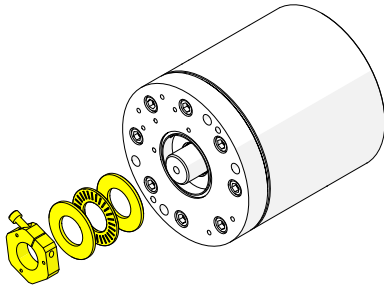

1. Loosen the clamp-nut locking screw with a $5/32$ -inch Allen wrench and then use a $1\ 1/2$ -inch socket to remove the clamp-nut.

2. Remove the thrust washers (2x) and the radial bearing beneath the clamp-nut.

3. Push the driveshaft straight out of the wrist motor.

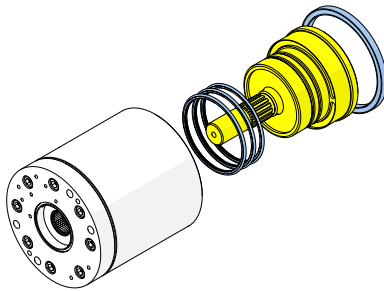

4. Do not rotate the driveshaft while removing it. Rotation can cause misalignment and will prevent the wrist motor from turning when reassembled.

5. Replace the flange seals and/or slipping seals as needed.

Installation

1. Place the driveshaft on a flat surface with the splined shaft up.

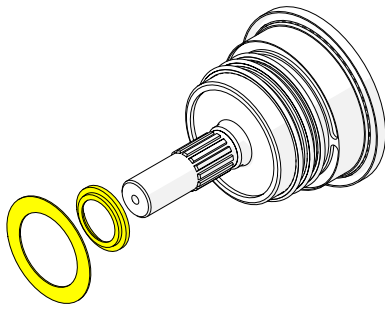

2. Install the backup seal, then the thrust washer onto the driveshaft.

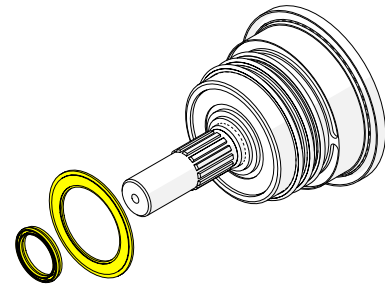

3. Lubricate the bearing and the seal.
4. Use enough lube to hold the parts in place when inverted.

5. Install the bearing and seal. Ensure that the seal is installed with the cup facing up.
6. Align the splines with the gerotor splines and press the wrist motor over the driveshaft until fully seated.
7. If the splines do not align properly, the motor will not rotate when reassembled. If this occurs, rebuild the wrist motor according to the provided instructions.

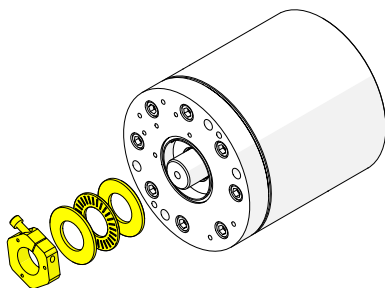

8. Install the thrust washer, radial bearing, and second thrust washer onto the driveshaft.

- 9.** Tighten the clamp-nut to the torque stamped on the nut with a 1 1/2-inch socket.

A stamp of "10" = 10 lbf-ft

- 10.** Tighten the locking screw with a 5/32-inch Allen wrench.
- 11.** Turn the motor over and push the flange seal into the gap between the driveshaft and motor housing.

Wrist Motor Rebuild

Disassembly

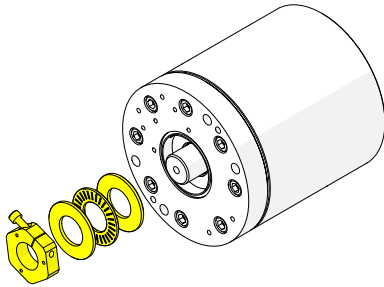

1. Loosen the clamp-nut locking screw with a $5/32$ -inch Allen wrench and then use a $1\ 1/2$ -inch socket to remove the clamp-nut.

2. Remove the thrust washers (2x) and the radial bearing beneath the clamp-nut.
3. Push the driveshaft out of the wrist motor.
4. Loosen the 8x SHCS with a $1/4$ -inch Allen wrench.
5. Remove the back of the wrist motor with the bolts in place.

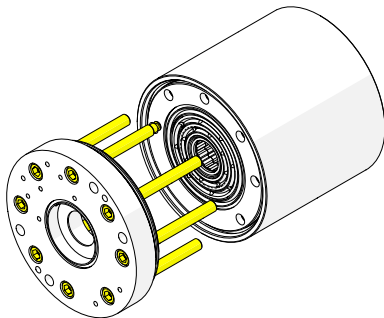

6. Remove the valve plate.

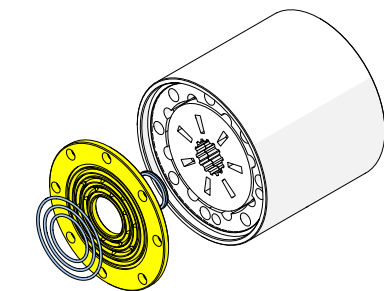

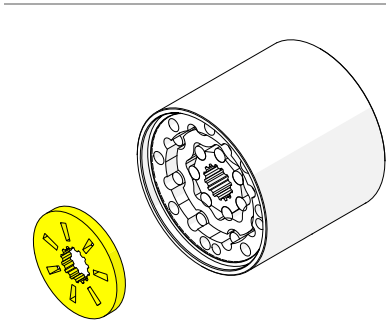

7. Remove the timing plate.

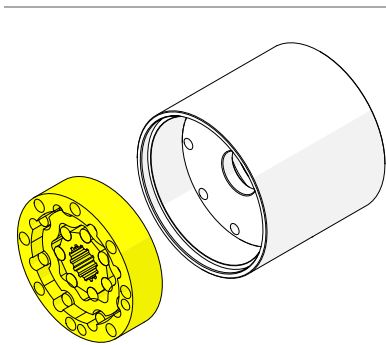

8. Remove the gerotor assembly.

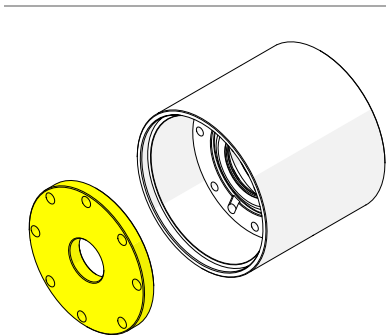

9. Remove the wear plate.

10. Remove and replace all seals and O-rings as required.

Reassembly

1. Place the driveshaft on a flat surface with the splined shaft up.

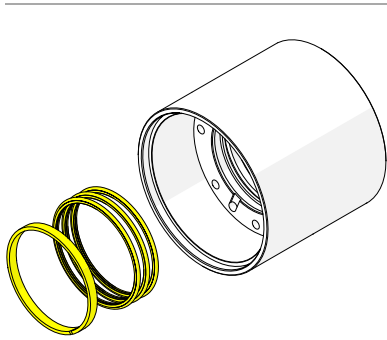

2. Install the slipping seals into the wrist housing.

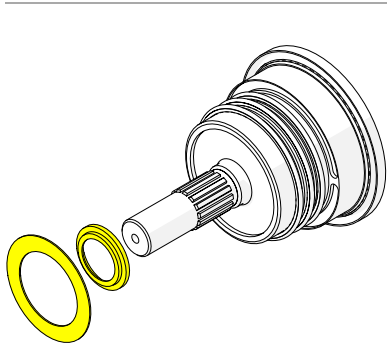

3. Install the backup seal, then the thrust washer onto the driveshaft.

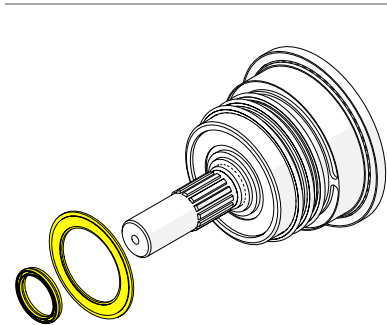

4. Lubricate the bearing and the seal.

5. Use enough lube to hold the parts in place when inverted.
6. Install the bearing and seal. Ensure that the seal is installed with the cup facing up.
7. Press the housing over the driveshaft.
8. Place the wear plate into the wrist housing. Rotate it until the bolt holes line up with the bolt holes in the housing. Press down until the seal slides into the wear plate.

9. Install the gerotor assembly, rotating the outer ring until it lines up with the bolt holes in the wear plate and housing.

⚠ *Install the outer ring of the gerotor with the narrow groove facing up.*

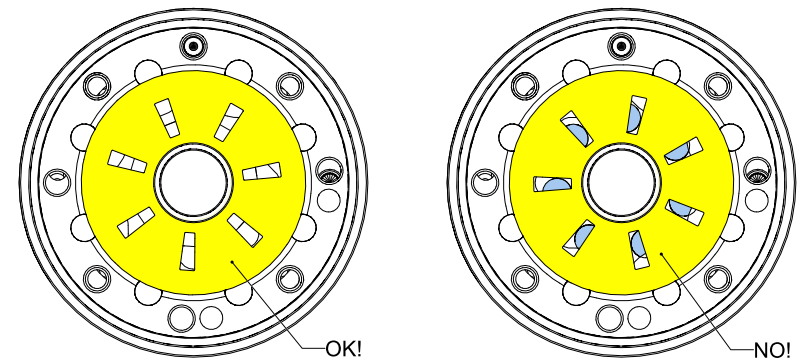

10. Install the timing plate, making sure that you are not able to see the rollers through the slots. If you can see the rollers, remove the timing plate and advance it by one spline tooth.

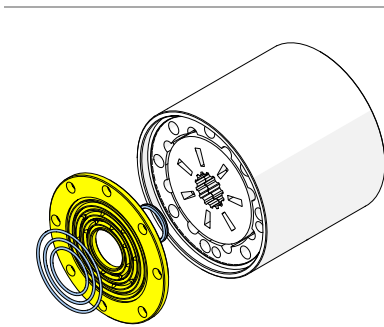

11. Place the shaft seal over the driveshaft with the cup side down.
12. Place the valve plate over the shaft with the O-ring grooves facing up. Rotate it until it aligns with the 8x bolt holes and press it down onto the seal.
13. Install the O-rings into the grooves in the valve plate.

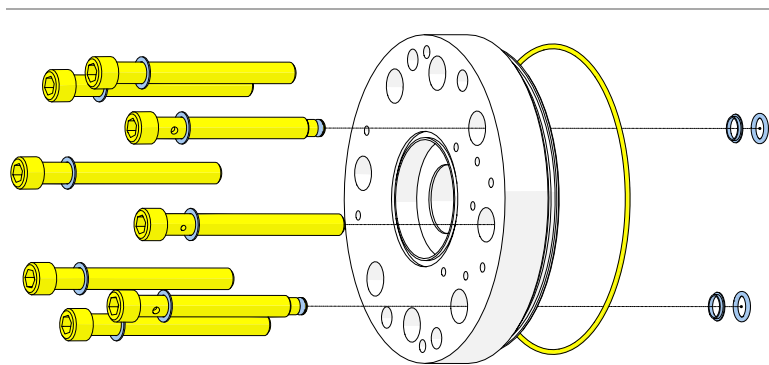

14. Install a crush washer onto each of the 8x bolts.
15. There are three drilled bolts. Only two of them have O-ring slots in the end.
16. Install O-rings onto the ends of the drilled bolts with slots.
17. Install the 2x drilled bolts (with O-rings) on either side of the small oil passages.
18. Install a bushing and O-ring on each of the 2x drilled bolts.
19. Install the drilled bolt (without an O-ring) in between the 2x O-ring bolts.
20. Install the remaining 5x bolts.
21. Install the O-ring around the outer diameter of the manifold.
22. Align the manifold with the holes in the gerotor and wrist housing and press it onto the driveshaft. Tighten the 8x bolts

 *Torque all bolts to 15 lbf-ft (20 Nm)*

Tighten all but the 2x drilled bolts with O-rings.

 *Torque 6x bolts to 19 lbf-ft (26 Nm)*

Tighten the 5x non-drilled bolts.

 *Torque 5x bolts to 24 lbf-ft (33 Nm)*

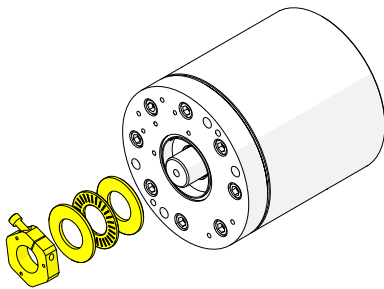

23. Install the thrust washer, radial bearing, and second thrust washer onto the driveshaft.
24. Tighten the clamp-nut to the torque stamped on the nut with a 1 1/2-inch socket.

 *A stamp of "10" = 10 lbf-ft*

25. Tighten the locking screw with a 5/32-inch Allen wrench.
26. Turn the motor over and push the flange seal into the gap between the driveshaft and motor housing.

Linear Actuator Remove and Replace

Tools

1 5/8-inch modified socket tool, vice, 1/2-inch drive breaker bar or ratchet, Bearing Installation & Removal tool (010-1457)

Personnel

Sub-Procedures

Parts-Kits

Safety

Consumables

LOCTITE

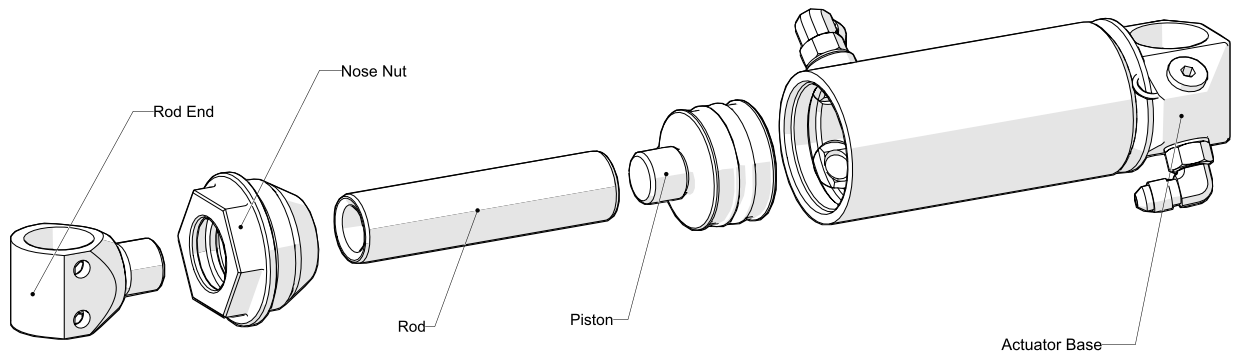

Disassembly

1. Place the **actuator base** in a vise.
2. Remove the **nose nut** using the special 1 5/8-inch modified socket tool.

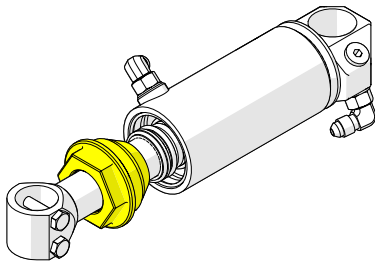

-
3. Pull the entire assembly out of the actuator housing.

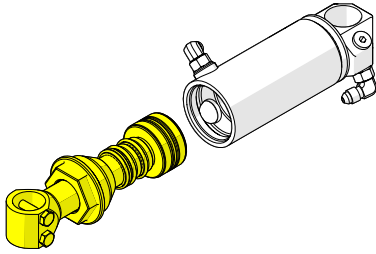

4. Place the **rod end** in a vise.
5. Use a 1/2-inch drive breaker bar or ratchet in the end of the piston to unthread the piston from the rod.

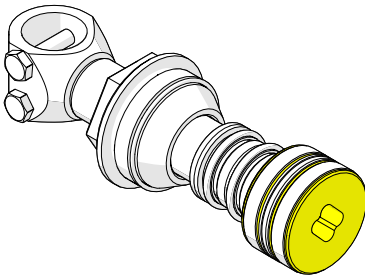

6. The rod and piston are assembled with LOCTITE. Using a heat-gun on the end that you wish to unthread will ensure that it comes out first.
7. Slide the nose nut off the actuator rod and remove any seals, O-rings or bearings that you will be replacing.

Reassembly

1. Clean any residual LOCTITE from the rod, piston and rod end.
2. Install new seals in the nose nut.
3. Install new bearing and seal on the piston using a sizing tool to stretch the seal onto the piston, and a resizing tool to shrink it to the original size.
4. Thread the resizing tool onto the rod and push the rod through the nose nut.
5. Add spacer (if used) to rod. Put LOCTITE on the threads of the piston and rod end and thread into the rod.

 *Torque to 75 lbf-ft (102 Nm).*

6. Add spacer(if used) to cylinder. Push the piston into the actuator housing and thread the nose nut into the housing.

 *Torque nose nut to 240lbf-ft (325 Nm).*

 ***The bearing must be installed on the piston before the piston seal to support the resizing tool. Failure to do so may damage to the resizing tool.***

Atlas Yaw Actuator

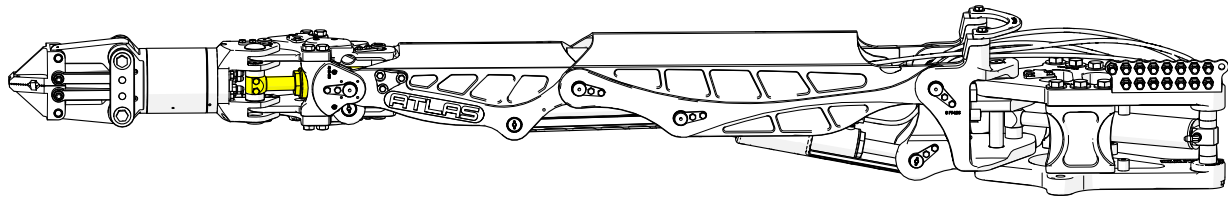

Removal

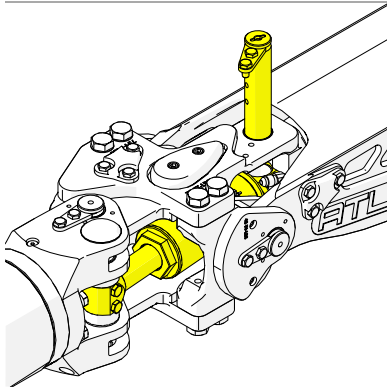

1. Remove the pin keepers and rod from the yaw actuator base with a 7/16-inch socket.

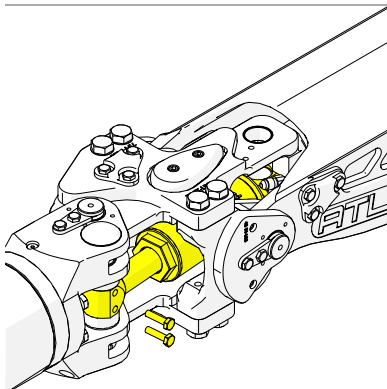

2. Remove the 2x bolts from the actuator rod end.

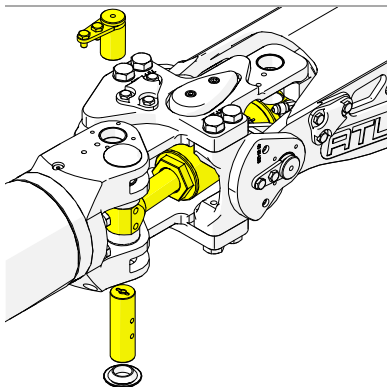

3. Remove the keepers and pins from the wrist base and then slide the wrist slightly forward to allow the yaw actuator pin and thrust washers to slide out of the wrist base.

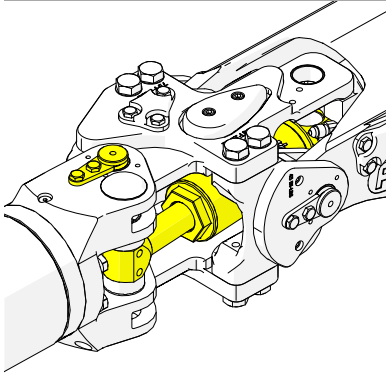

4. Reinstall the wrist base pins and keepers.

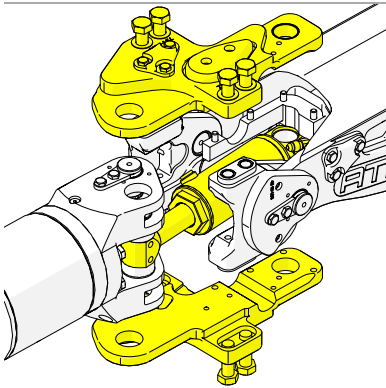

5. Remove the bolts and the upper and lower yaw plates with a 3/4-inch socket.

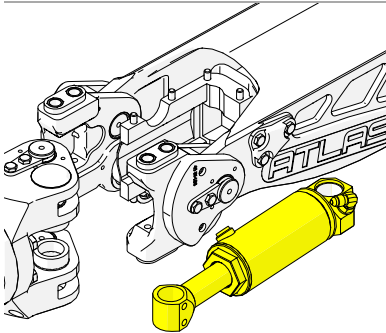

6. Slide actuator and actuator guard out of the arm and remove the 2 hoses with a 9/16-inch wrench.

Changing Manipulator Direction From Left to Right

Tools

Personnel

Sub-Procedures

Parts-Kits

Safety

Consumables

LOCTITE

Disassembly



WARNING! Before performing this procedure, make sure that the Atlas manipulator arm is on a secured surface such as a work bench. If not, the azimuth block can fall and cause a hazard when disconnected from the upper arm

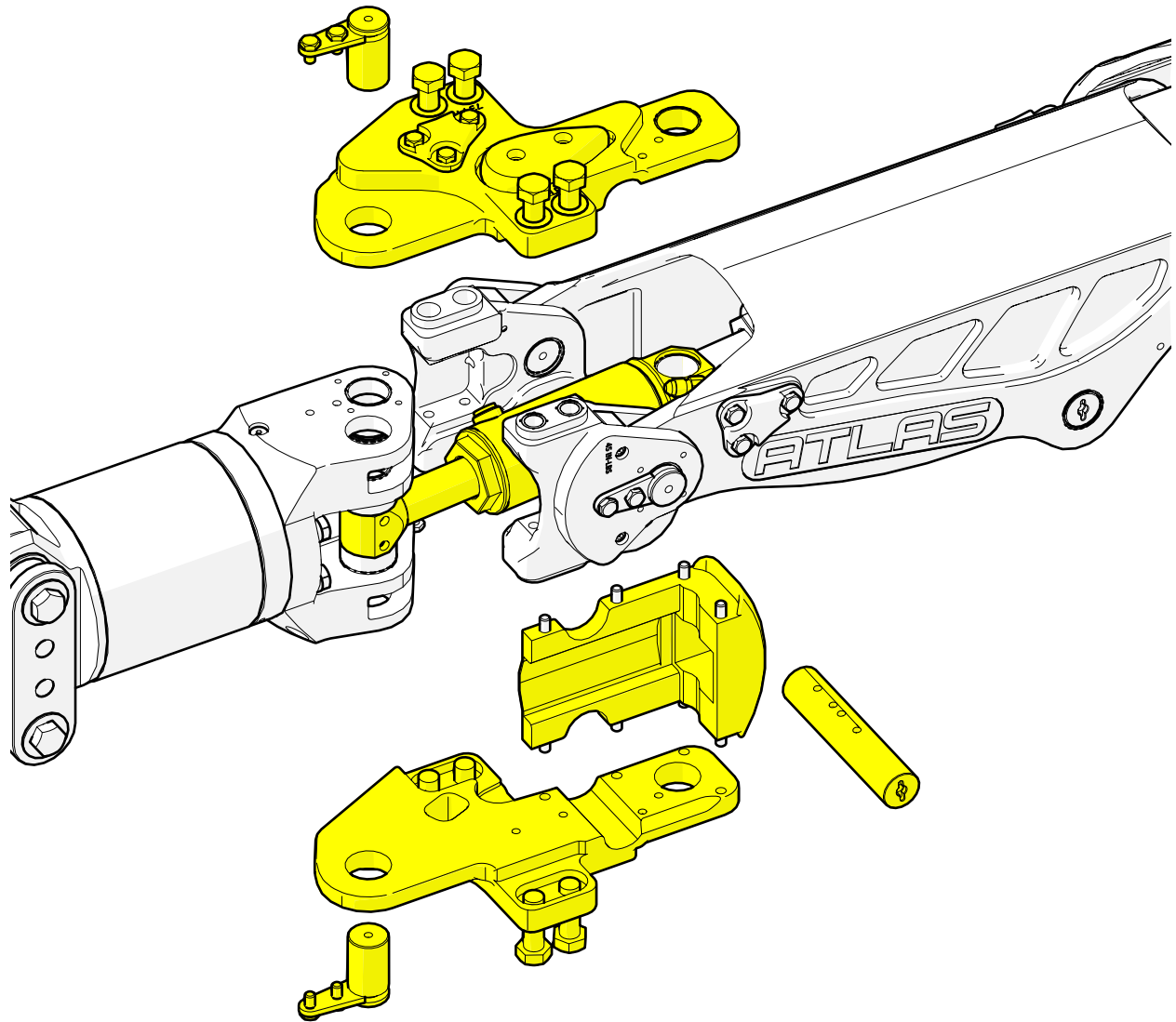

1. Remove the yaw actuator.

 See the *Yaw Actuator Service Instruction* for more information.

2. Remove the pitch actuator pivot pin with a 7/16-inch socket.
3. Remove the keepers, pivot pin and spacers at the elbow joint pivot with a 7/16-inch socket.
4. Remove the hose from the fitting at the base of the pitch actuator, rotate the actuator so the fitting is on the underside of the arm, and re-install the hose with a 9/16-inch wrench.
5. Move the yaw plate that was on top to the bottom and reattach to the yaw pivot plates with a 3/4-inch socket.
6. Place the yaw actuator guard into position, but do not attach at this time.
7. Install the remaining yaw plate on the top of the yaw assembly and attach with a 3/4-inch socket.
8. Reinstall the pitch actuator rod end pin with a 7/16-inch socket.
9. Switch the location of all four fittings on the yaw actuator. Move both plugs to where the 90 degree fittings are located.

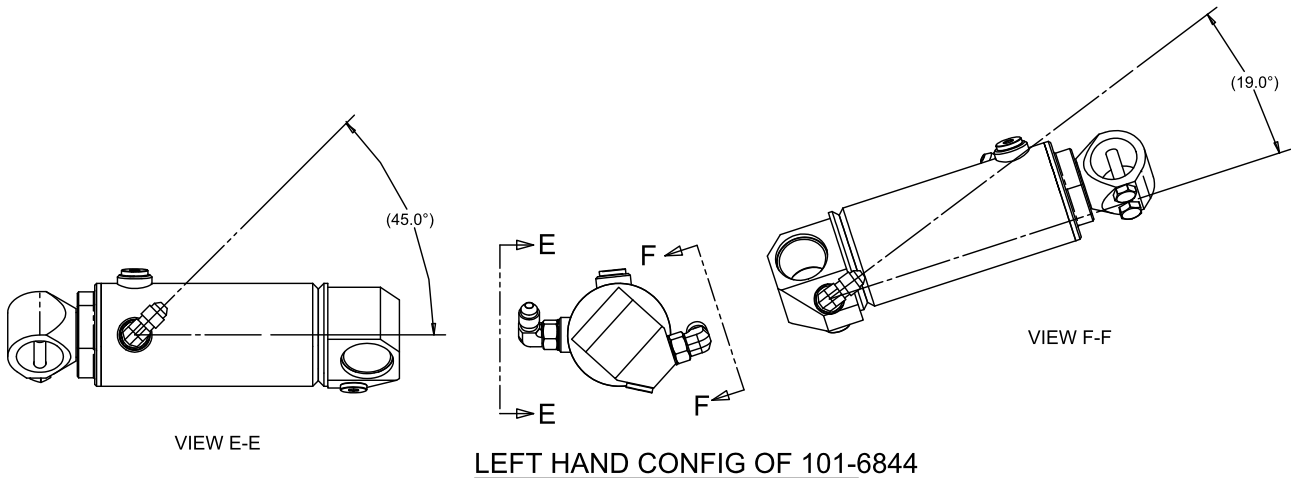

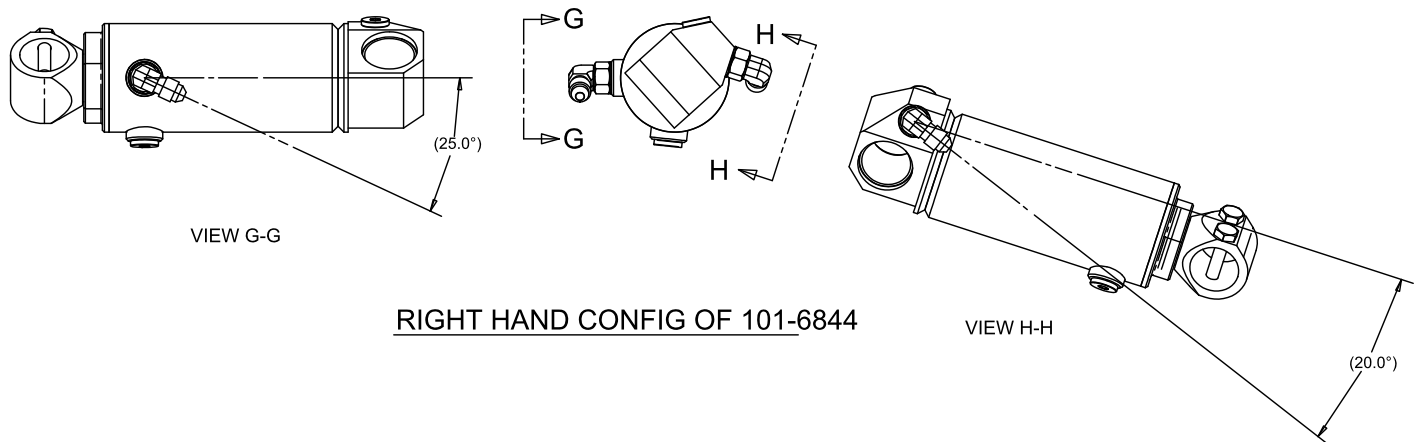

- 10.** Attach the front yaw actuator hose only.
- 11.** Slide the actuator into the guard.
- 12.** Attach the rear hose.
- 13.** Attach the pin at the base of the actuator.
- 14.** Remove the pivot pins at the yaw pivot, and then install the yaw actuator rod pin and attach with 2x HHCS.
- 15.** Reinstall the yaw pivot pins.

Pitch Actuator Replacement

Tools

Personnel

Sub-Procedures

Parts-Kits

Safety

Consumables

LOCTITE

Removal

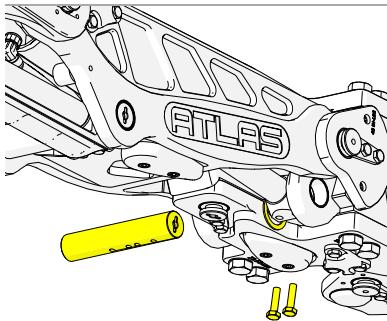

1. Remove the keeper, pivot pin, and thrust bearings at the pitch actuator rod end with a 7/16-inch socket.

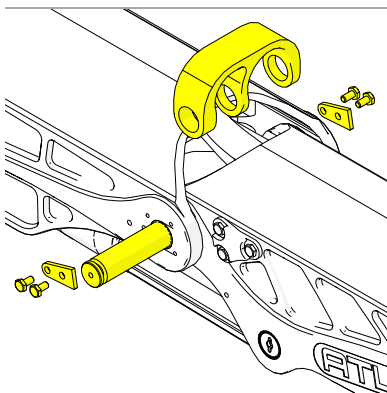

2. Remove the keepers, pivot pin, and spacers at the elbow joint.

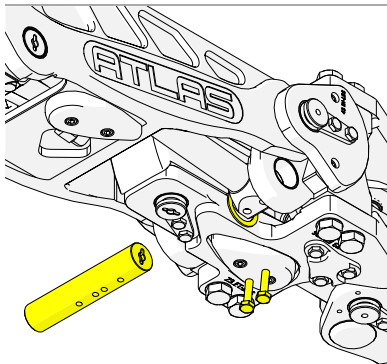

3. Pull the actuator out of the forearm at the elbow joint.

4. Remove the hoses with a 9/16-inch wrench

Installation

- 1.** Orient the fittings for left or right hand operation.
- 2.** Place the actuator in the forearm for left or right hand operation.
- 3.** Reinstall the elbow pivot pin, spacers, and keepers.
- 4.** Reinstall the rod end pivot pin, thrust bearings, and keepers.

Atlas Forearm Segment

Tools

Personnel

Sub-Procedures

Parts-Kits

Safety

Consumables

LOCTITE

Removal

1. Remove hoses C, 6A, 6B, 5A, 5B, 4A, 4B at the base manifold.
2. Remove the pitch actuator using prior instructions.
3. Remove the keepers and pins at the pitch pivot with a 7/16-inch socket.

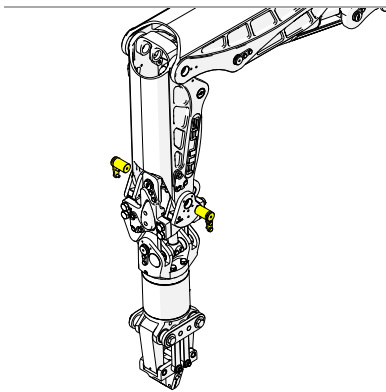

4. Remove the pin, thrust bearing, and keeper at the elbow actuator rod end with a 7/16-inch socket.

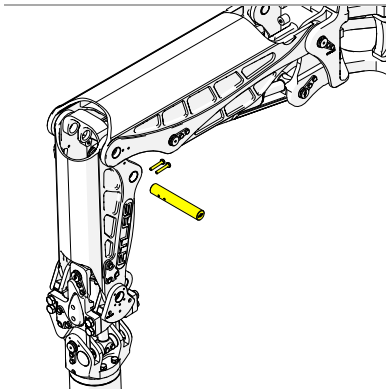

5. Slide the hoses out of the upper arm and forearm.

Reassembly

- 1.** Feed hoses C, 6A, 6B, 5A, 5B, 4A, 4B through the forearm and upper arm and attach to the base manifold.
- 2.** Install the pin, spacers and keeper for the elbow actuator rod end into the forearm.
- 3.** Install the elbow pivot pin, spacers and keepers through the upper arm, forearm and pitch actuator base.
- 4.** Install the pitch actuator using prior instructions.

Atlas Upper Arm Segment

Tools

Personnel

Sub-Procedures

Parts-Kits

Safety

Consumables

LOCTITE

Removal

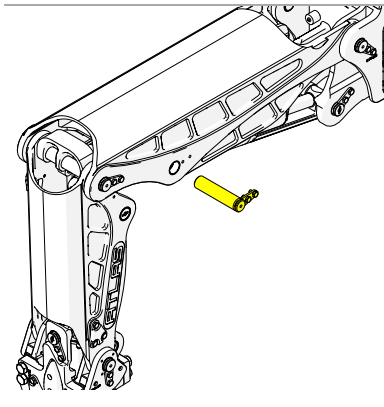

1. Remove the shoulder actuator pin, thrust bearings and keeper in the upper arm with a 7/16-inch socket.

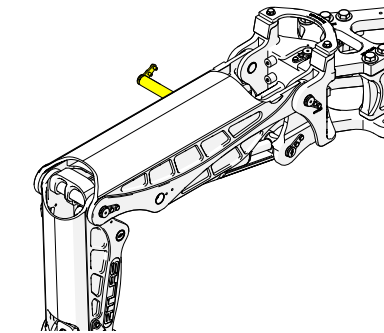

2. Remove the elbow actuator pin, thrust bearing and keeper in the upper arm with a 7/16-inch socket.
3. Remove hose 1A from the base of the shoulder actuator with a 9/16-inch wrench.

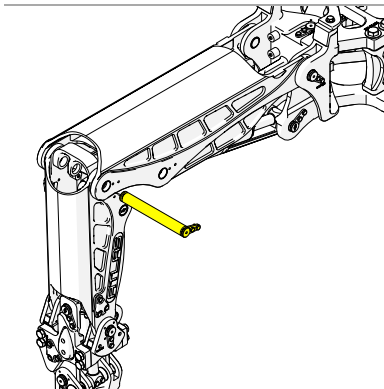

4. Remove the pin, spacers, and keepers from the elbow pivot.
5. Remove hoses 2A, 2B, 3A, 3B, 4A, 4B, 5A, 5B, 6A, 6B, C from the base manifold.

6. Remove the pins and keepers from the shoulder pivots.
7. Slide the hoses out of the upper arm.

Azimuth Block Remove and Replace

Tools

Personnel

Sub-Procedures

Parts-Kits

Safety

Consumables

LOCTITE

 **WARNING!** Before performing this procedure, make sure that the Atlas manipulator arm is on a secured surface such as a work bench. If not, the azimuth block can fall and cause a hazard when disconnected from the upper arm.

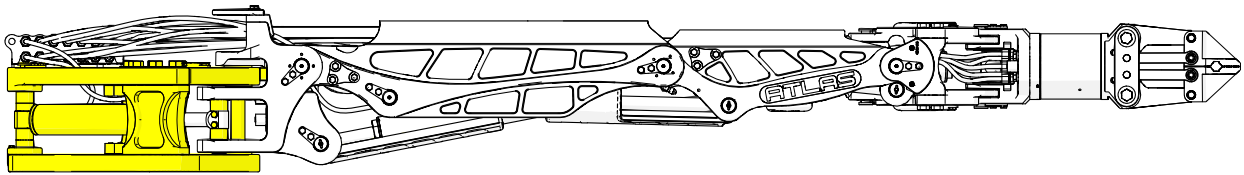

Disassembly

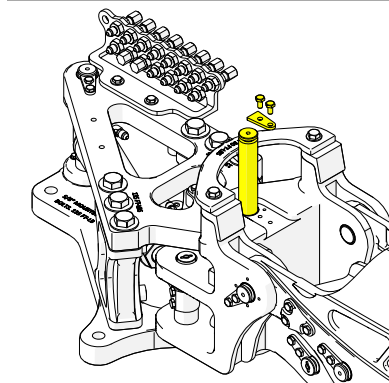

1. Remove the shoulder actuator pin, thrust bearings, and keeper in the upper arm with a 7/16-inch socket.
2. Disconnect the hydraulic hoses from the manifold.

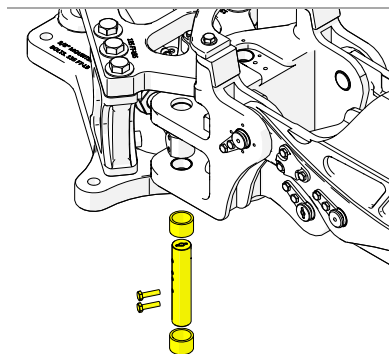

3. Remove the 2x retaining bolts, azimuth actuator pin, and thrust bearings in the upper arm with a 7/16-inch socket.

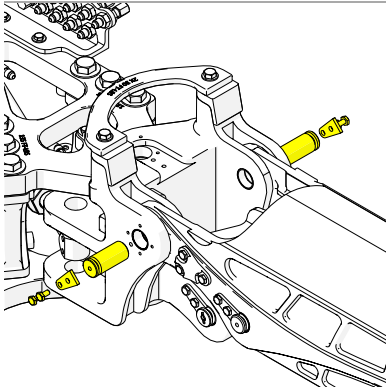

4. Remove the shoulder segment pivot pins and keepers with a 7/16-inch socket.

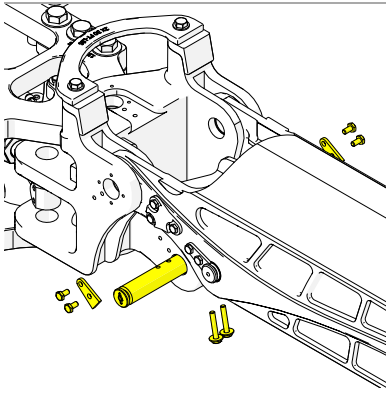

5. Remove the 2x keepers, 2x retaining bolts, and azimuth pivot pins with a 7/16-inch socket.

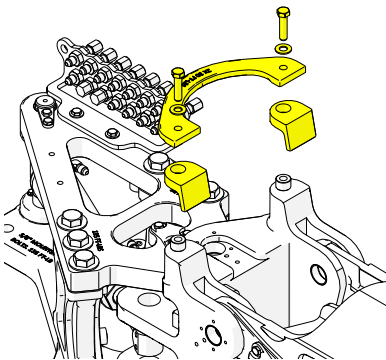

6. Remove the hose guide and hard stops with a 7/16-inch socket to allow the hoses to come free of the azimuth.

Reassembly

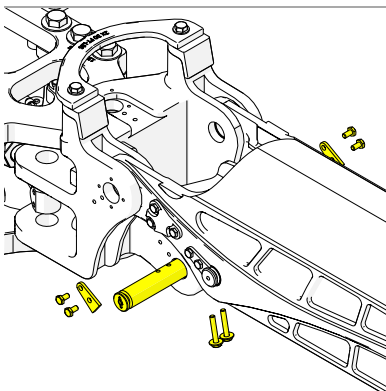

1. Install the azimuth pivot pin, 2x keepers, and 2x retaining bolts.

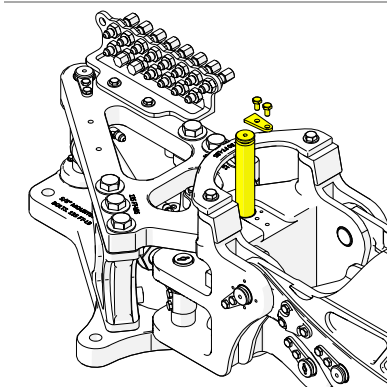

2. Install the azimuth actuator pin, spacers, and bolts.

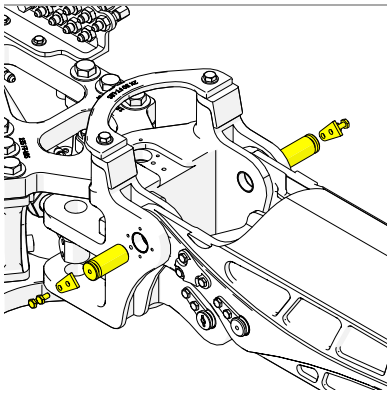

3. Install the shoulder pivot pins and keepers, and bolts.

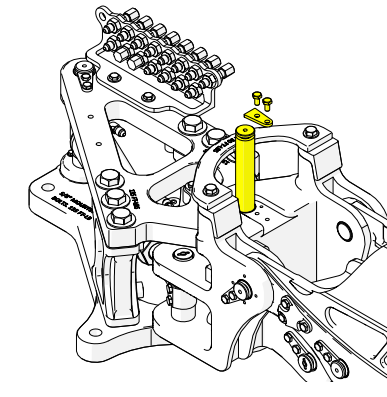

4. Install the shoulder actuator pin, keepers, and bolts.

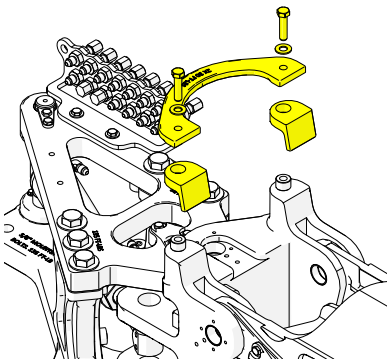

5. Install the hose guide and hard stops, and bolts.

6. Reconnect the hydraulic hoses to the manifold.

Atlas Base Remove and Replace

Tools

Personnel

Sub-Procedures

Parts-Kits

Safety

Consumables

LOCTITE

 **WARNING!** Support the Atlas manipulator arm to prevent injury or damage to the manipulator.

 **WARNING!** Before performing this procedure, make sure that the Atlas manipulator arm is on a secured surface such as a work bench. If not, the azimuth block can fall and cause a hazard when disconnected from the upper arm.

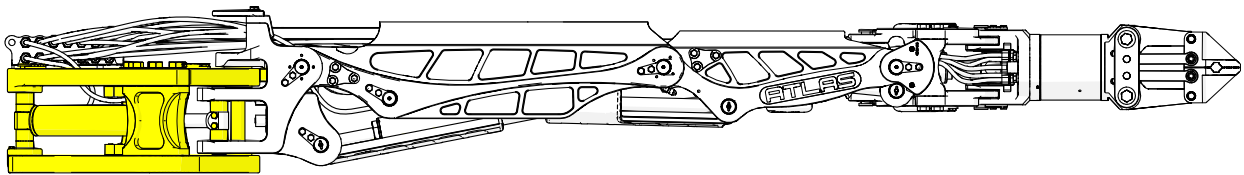

Disassembly

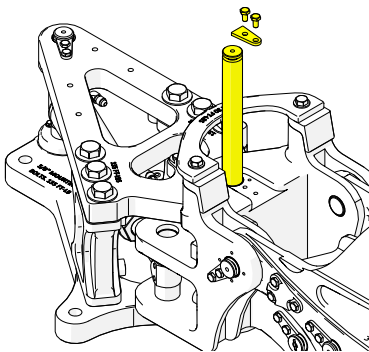

1. Remove the azimuth actuator pin, thrust bearings, and keeper with a 7/16-inch socket.
2. Disconnect the hydraulic hoses from the manifold.

-
3. Remove the hose manifold with a 7/16-inch socket.

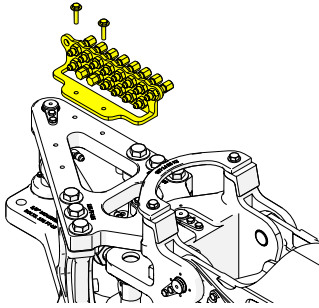

4. Remove the azimuth pivot pin and keeper with a 7/16-inch socket.

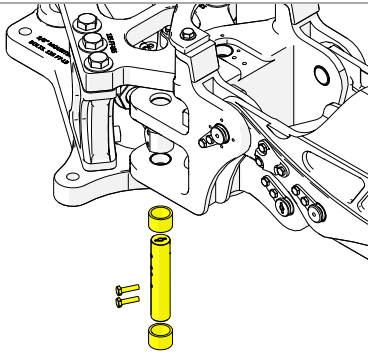

5. Remove the azimuth actuator pin from the base of the actuator by removing the lower hidden keeper with a 3/8-inch socket. Remove the upper keeper and bolts with a 7/16-inch socket.

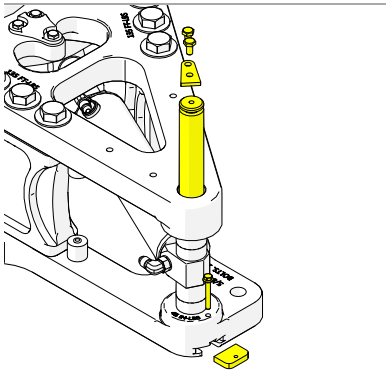

6. Remove the azimuth actuator.

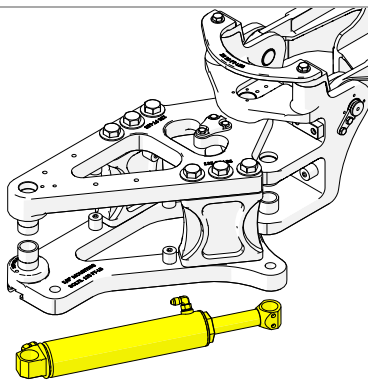

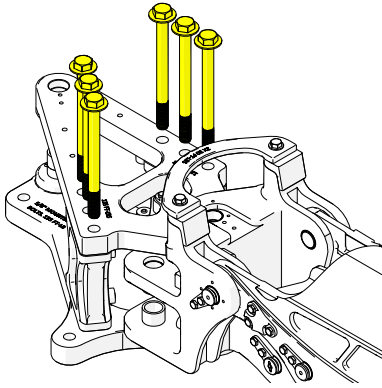

7. To completely disassemble the base, remove the 6x bolts with a 3/4-inch socket.

Reassembly

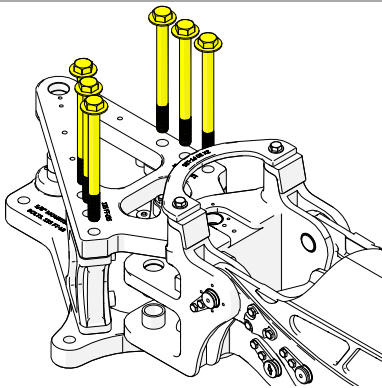

1. Install and torque the 6x 5/8-inch fasteners with a 3/4-inch socket.

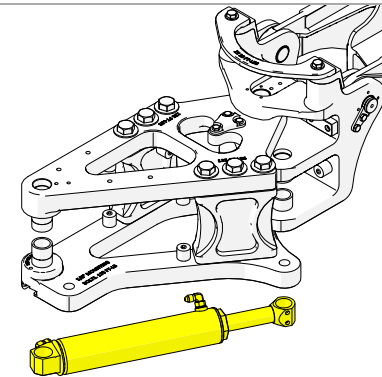

2. Install the azimuth actuator.

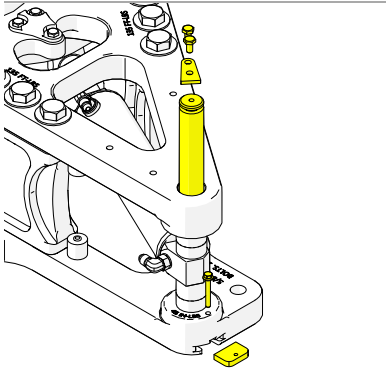

3. Install the azimuth actuator rear pin, upper and lower keepers, spacers and bolts.

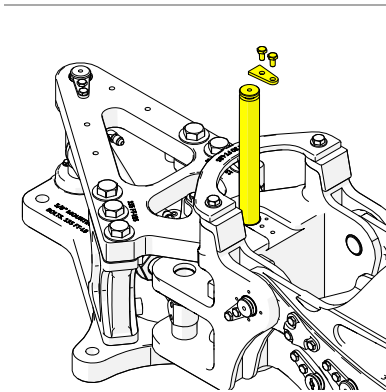

4. Install the azimuth pivot pin and keepers.

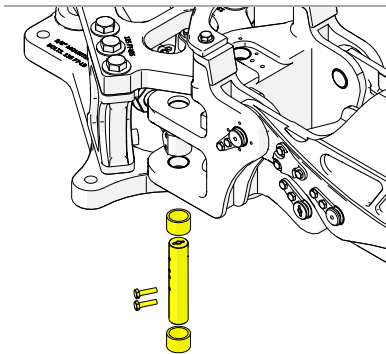

5. Install the azimuth actuator pin, spacers, and bolts.

 (Models 199-0292-x only) Install the hose manifold.

6. Reconnect the hydraulic hoses to the manifold.

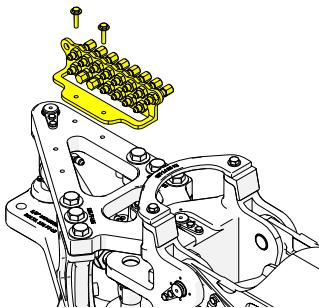

Atlas Typical Bushing Replacement

Part # 010-1457 -Bushing Replacement Tool

Bushing Removal

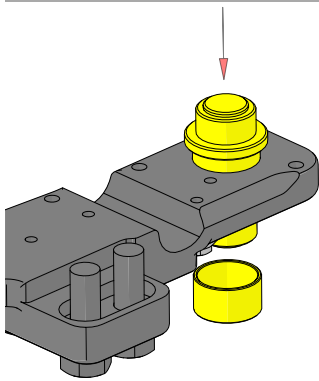

Use special tool 010-1457 (Bushing Removal tool) to press out the part.

Bushing Installation

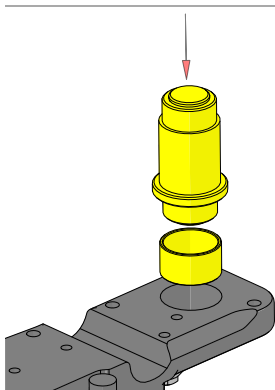

1. Clean the bushing and the bore with acetone or LOCTITE primer.
2. Apply LOCTITE to the bore and the bushing.
3. Use the bushing installation tool to press the bushing into the part.

Drawings, Schematics, Part Lists

- Spares Kit 008-0506 65
- Spares Kit 008-0216 (Item 1 in Spares Kit 008-0506) 66
- Spares Kit 008-0509 (Item 3 in Spares Kit 008-0506) 66
- Spares Kit 008-0510 (Item 4 in Spares Kit 008-0506) 67
- Spares Kit 008-0096 (Item 6 in Spares Kit 008-0506) 67
- Tool Kit 010-1386 68
- Atlas Hydraulic Schematic 025-0132 69
- Hose Routing, Left Hand Configuration 70
- Hose Routing, Right Hand Configuration 71
- Linear Actuators 72
- Anodes and Bump Stops 73
- Bushings and Inserts 74
- Sensor Covers 75
- Pins and Spacers 76
- Major Structures 77
- Linear Actuators 78
- Wrist, 101-3786 79
- Jaw, 101-3299 80
- Jaws, 101-3569 81
- Noseblock, 101-3853 82

Spares Kit 008-0506

SPS KIT,A7F, 008-0506, REV A			
Item	P/N	Description	Qty
1	008-0216	KIT,SOFT GOODS,LIN ACTR,T3	2
3	008-0509	SPS KIT,ATLAS,HOSES	1
4	008-0510	SPARES KIT,ATLAS,HDW	1
6	008-0096	SP KIT, RIG, WRIST	1

Spares Kit 008-0216 (Item 1 in Spares Kit 008-0506)

KIT,SOFT GOODS,LIN ACTR,T3, 008-0216, REV A			
Item	P/N	Description	Qty
7	003-0115	BRG,PSTN,LIN ACTR,T2 GAMMA	2
8	004-0649	SEAL,PSTN,LIN ACTR,T2/3,GAMMA	1
9	004-0669	O-RING,2-031,BUNA 90	1
10	001-0893	BRG,ROD	2
11	004-0650	SEAL,ROD,LIN ACTR,GAMMA	2
12	004-0651	SCRAPER,ROD,LIN ACTR,T2 GAMMA	1
14	004-0082	O-RING,3-904 BUNA 90	2

Spares Kit 008-0509 (Item 3 in Spares Kit 008-0506)

SPS KIT,ATLAS,HOSES, 008-0509, REV A			
Item	P/N	Description	Qty
2	006-2613-1	HOSE,-4 JIC,56-DH,73.75 LG	1
3	006-2613-2	HOSE,-4 JIC,56-DH,72.75 LG	1
4	006-2613-3	HOSE,-4 JIC,56-DH,74.50 LG	1
5	006-2613-4	HOSE,-4 JIC,56-DH,73.50 LG	1
6	006-2613-5	HOSE,-4 JIC,56-DH,79.25 LG	1
7	006-2613-6	HOSE,-4 JIC,56-DH,69.25 LG	1
8	006-2613-7	HOSE,-4 JIC,56-DH,75.75 LG	1
9	006-2613-8	HOSE,-4 JIC,56-DH,62.00 LG	1
10	006-2613-9	HOSE,-4 JIC,56-DH,28.50 LG	1
11	006-2613-10	HOSE,-4 JIC,56-DH,41.75 LG	1
12	006-2613-11	HOSE,-4 JIC,56-DH,42.25 LG	1
13	006-2613-12	HOSE,-4 JIC,56-DH,32.00 LG	1
14	006-2613-13	HOSE,-4 JIC,56-DH,15.50 LG	1
15	006-2613-14	HOSE,-4 JIC,56-DH,17.00 LG	1
16	006-2613-15	HOSE,-4 JIC,56-DH,72.50 LG	1

Spares Kit 008-0510 (Item 4 in Spares Kit 008-0506)

SPARES KIT,ATLAS,HDW, 008-0510, REV A			
Item	P/N	Description	Qty
1	001-4342	RETAINER, PIN	3
2	002-0029P	HHCS, 1/4-20 X 1/2, SS, PATCH	6
3	003-0114	BRG, PVT, LIN ACTR, T2 GAMMA	2
4	002-1440	ANODE, GALVANIC	8
5	002-0229P	SHCS, 10-24 X 3/8, SS, PATCH	4
6	002-0195	SHCS, 10-24X1-1/4, SS	4
7	003-0298	BRG, THRUST, 1"IDX1.75"OD"X.0585	2
8	003-0263	BRG, DIXON, CJ16E18-5	10
9	001-10523	BRNG, TOP HAT, 1.0 ID, .735 LG	4
10	003-0263-2	BEARING, DIXON, 1.0X1.125X.438L	5
12	003-0263-1	BRG, DIXON, 1.0 ID X .530 LG	2
13	001-10743	HARD STOP, SHOULDER, A7F	2
14	001-10492	HARD STOP, AZIMUTH, A7F	2
15	001-10538	STOP, PITCH, A7F	2
16	001-7520	BOLT, 6 PT, 5/8-18, STD	2
17	001-5396	PLATE, T-BAR, LOCKING	2
18	002-1925	ANTI-SIEZE, 1 OZ TUBE	1
19	001-10493	SPACER, HARD STOP, AZIMUTH, A7F	2
20	002-3168	ANODE, T-20	5
21	002-0966	SHCS, 1/4-20X.75, SS	2
22	002-0188	HHCS, 1/4-20X1.5, SS	4
23	002-0715P	HHCS, 1/2-20X1.5, 316SS, NLK	4

Spares Kit 008-0096 (Item 6 in Spares Kit 008-0506)

SP KIT, RIG, WRIST, 008-0096, REV B			
Item	P/N	Description	Qty
1	004-0222	O-RING, 2-010 BUNA 90	5
2	003-0174	BSHG, FL., 1/4X5/16X1/4LG., NYL	1
3	004-0617	SEAL, FLUROCARBON #AR10400-418-	1
4	002-1544	WSHR, G10, 5/16X9/16X1/16	1
5	004-0803	SEAL, SHAMBAN, TGZF-S4016NA	3

SP KIT, RIG, WRIST, 008-0096, REV B (continued)			
Item	P/N	Description	Qty
7	001-4454	BRG,SLYDRING,2.875IDX3.063X.25	1
8	003-0074	WSHR,THR,TRA2840,TORRINGTON	1
9	003-0013	TORRINGTON,NTA 2840	1
12	004-0575	SEAL,AR10103-214-UH,FLUROCARBO	1
15	004-0574	SEAL,AR10103-212-UH,FLUROCARBO	1
16	004-0081	O-RING,2-035 BUNA 70	1
17	004-0017	O-RING,2-031 BUNA 70	2
18	004-0413	O-RING,2-026 V75	1
19	004-0110	O-RING,2-046 BUNA 70	1
22	001-4448	BOLT,OIL SPLY,WR	2
23	001-4449	BOLT,OIL RTN,WR	1
24	004-0445	O-RING,2-006 V90	2
25	001-1984	BSHG,WR OIL SPLY TUBE	2
26	004-0698	O-RING,2-011,DISOGRIN 90 DURO	5
27	004-0576	WSHR,CRUSH,5/16	16
29	001-4577	SHCS,5/16-18X3,CADMIUM PLD,UNB	5
30	003-0092	WSHR,THR,TORRINGTON #TRC 1427	2
31	003-0091	BRG,THR,TORRINGTON #NTC 1427	1
33	002-0139	SHCS,10-32X3/4,SS	1
34	003-0078	BRG,CJ08E10-4,DIXON,.5X.625X.5	4
36	001-2946	BRG,2.25 BORE PSTN,GAMMA	2
37	004-0616	SEAL,PSTN,SHAMBAN,34G02250-A46	1
39	004-0542	O-RING,2-034 BUNA 70	1
40	004-0541	RING,BACKUP,8-034 BUNA 90	1
41	001-0893	BRG,ROD	2
42	004-0508	STEPSEAL,S48270-4203-109P	2
44	004-0619	O-RING,2-114,N90	1
48	003-0050	BRG,CJ12E144 DIXON	4
49	004-0650	SEAL,ROD,LIN ACTR,GAMMA	0

Tool Kit 010-1386

TOOL KIT,7F,ATLAS, 010-1386, REV A			
Item	P/N	Description	Qty
1	010-0173	TOOL,CLP,JAW	1
2	010-0174	TOOL,INSTALL,M,2.25	1

TOOL KIT,7F,ATLAS, 010-1386, REV A (continued)

Item	P/N	Description	Qty
3	010-0175	TOOL, SIZING, F, 2.25	1
4	010-0804	TOOL, PISTON ROD, JAW	1
5	010-0184	TOOL, INSTL, M, 1.75	1
6	010-0185	TOOL, SIZING, F, 1.75	1
7	010-0203	TOOL, SIZING, M, 1.0	1
8	010-0486	SKT, MOD, NOSE NUT, LIN ACT.	1
9	010-0804-1	TOOL, PSTN ROD, JAW, SIDE SKIRT	1
10	010-1455	TOOL, CLAMP, ACTUATOR ROD, 1 IN	2
11	010-1456	TOOL, PIN ALIGN ASSY	1
12	010-1457	TOOL, BEARING INSTL & RMV	1
13	010-1084	ADAPTER, SOCKET, 1/2" F TO 3/4" M	1

Atlas Hydraulic Schematic 025-0132

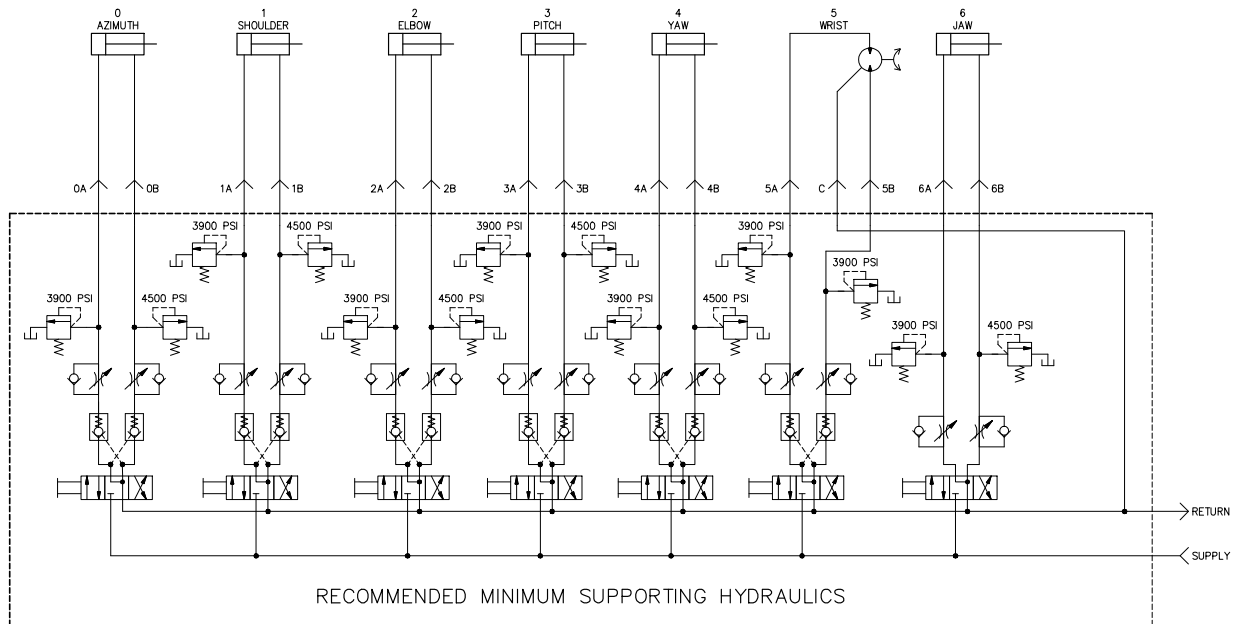

Hose Routing, Left Hand Configuration

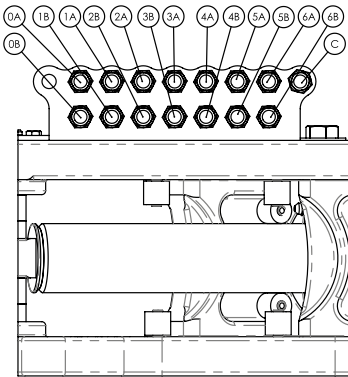
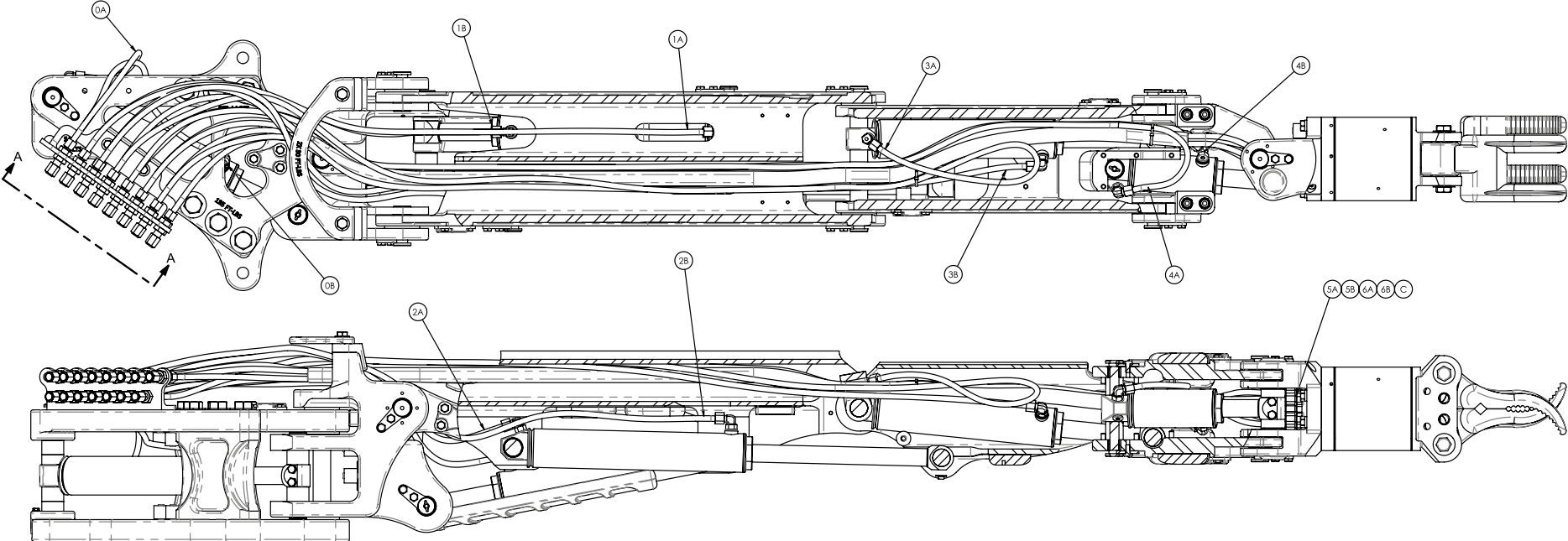

SECTION A-A
SCALE 1 : 2

FITTING DESIGNATOR					
HOSE	PART #	DESCRIPTION	HOSE	PART #	DESCRIPTION
0A	006-2613-13	HOSE-4 JIC.56-DH.15.50 LG	0B	006-2613-14	HOSE-4 JIC.56-DH.17.00 LG
1A	006-2613-11	HOSE-4 JIC.56-DH.42.25 LG	1B	006-2613-12	HOSE-4 JIC.56-DH.32.00 LG
2A	006-2613-9	HOSE-4 JIC.56-DH.28.50 LG	2B	006-2613-10	HOSE-4 JIC.56-DH.41.75 LG
3A	006-2613-7	HOSE-4 JIC.56-DH.75.75 LG	3B	006-2613-8	HOSE-4 JIC.56-DH.62.00 LG
4A	006-2613-5	HOSE-4 JIC.56-DH.79.25 LG	4B	006-2613-6	HOSE-4 JIC.56-DH.69.25 LG
5A	006-2613-3	HOSE-4 JIC.56-DH.74.50 LG	5B	006-2613-4	HOSE-4 JIC.56-DH.73.50 LG
6A	006-2613-1	HOSE-4 JIC.56-DH.73.75 LG	6B	006-2613-2	HOSE-4 JIC.56-DH.72.75 LG
C	006-2613-15	HOSE-4 JIC.56-DH.72.50 LG			

LEFT HAND CONFIGURATION
HOSE ROUTING SHEET
SOME ITEMS REMOVED FOR CLARITY

Hose Routing, Right Hand Configuration

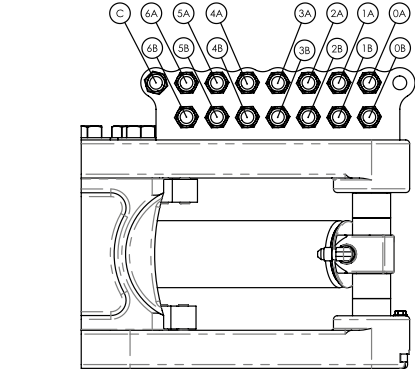
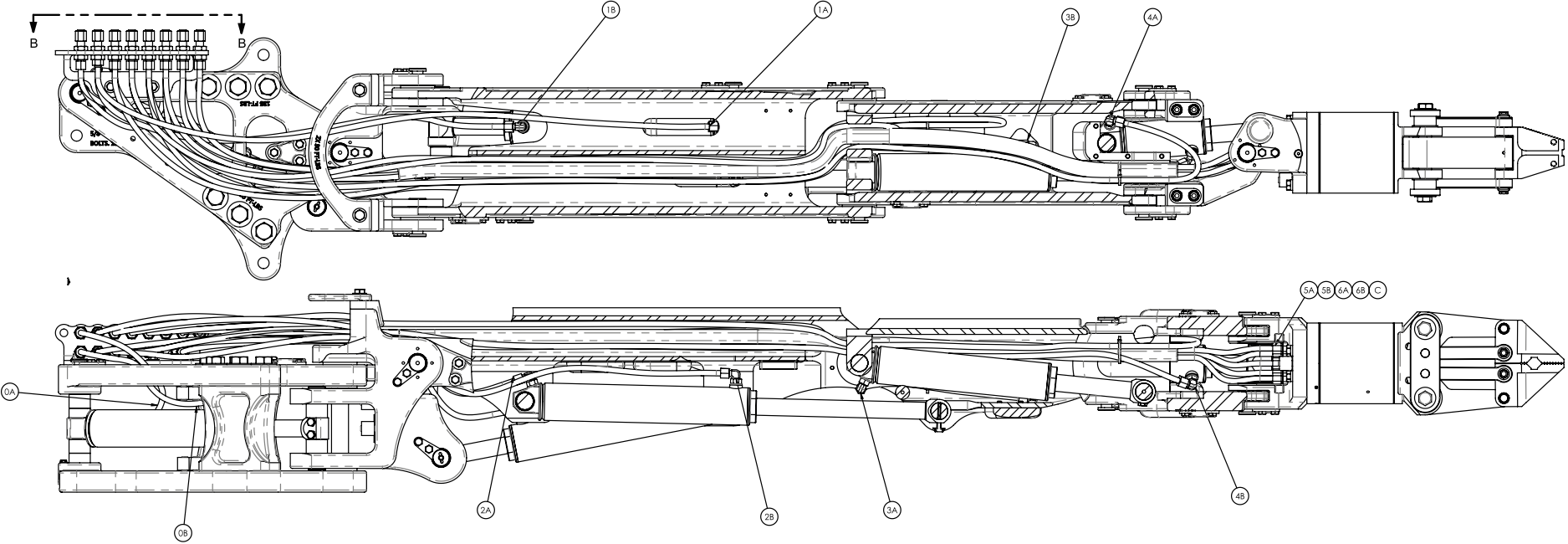

VIEW B-B
SCALE 1 : 2

FITTING DESIGNATOR					
HOSE	PART #	DESCRIPTION	HOSE	PART #	DESCRIPTION
0A	006-2613-13	HOSE-4 JIC,56-DH,15.50 LG	0B	006-2613-14	HOSE-4 JIC,56-DH,17.00 LG
1A	006-2613-11	HOSE-4 JIC,56-DH,42.25 LG	1B	006-2613-12	HOSE-4 JIC,56-DH,32.00 LG
2A	006-2613-9	HOSE-4 JIC,56-DH,28.50 LG	2B	006-2613-10	HOSE-4 JIC,56-DH,41.75 LG
3A	006-2613-7	HOSE-4 JIC,56-DH,75.75 LG	3B	006-2613-8	HOSE-4 JIC,56-DH,62.00 LG
4A	006-2613-5	HOSE-4 JIC,56-DH,79.25 LG	4B	006-2613-6	HOSE-4 JIC,56-DH,69.25 LG
5A	006-2613-3	HOSE-4 JIC,56-DH,74.50 LG	5B	006-2613-4	HOSE-4 JIC,56-DH,73.50 LG
6A	006-2613-1	HOSE-4 JIC,56-DH,73.75 LG	6B	006-2613-2	HOSE-4 JIC,56-DH,72.75 LG
C	006-2613-15	HOSE-4 JIC,56-DH,72.50 LG			

RIGHT HAND CONFIGURATION
HOSE ROUTING SHEET
SOME ITEMS REMOVED FOR CLARITY

Linear Actuators

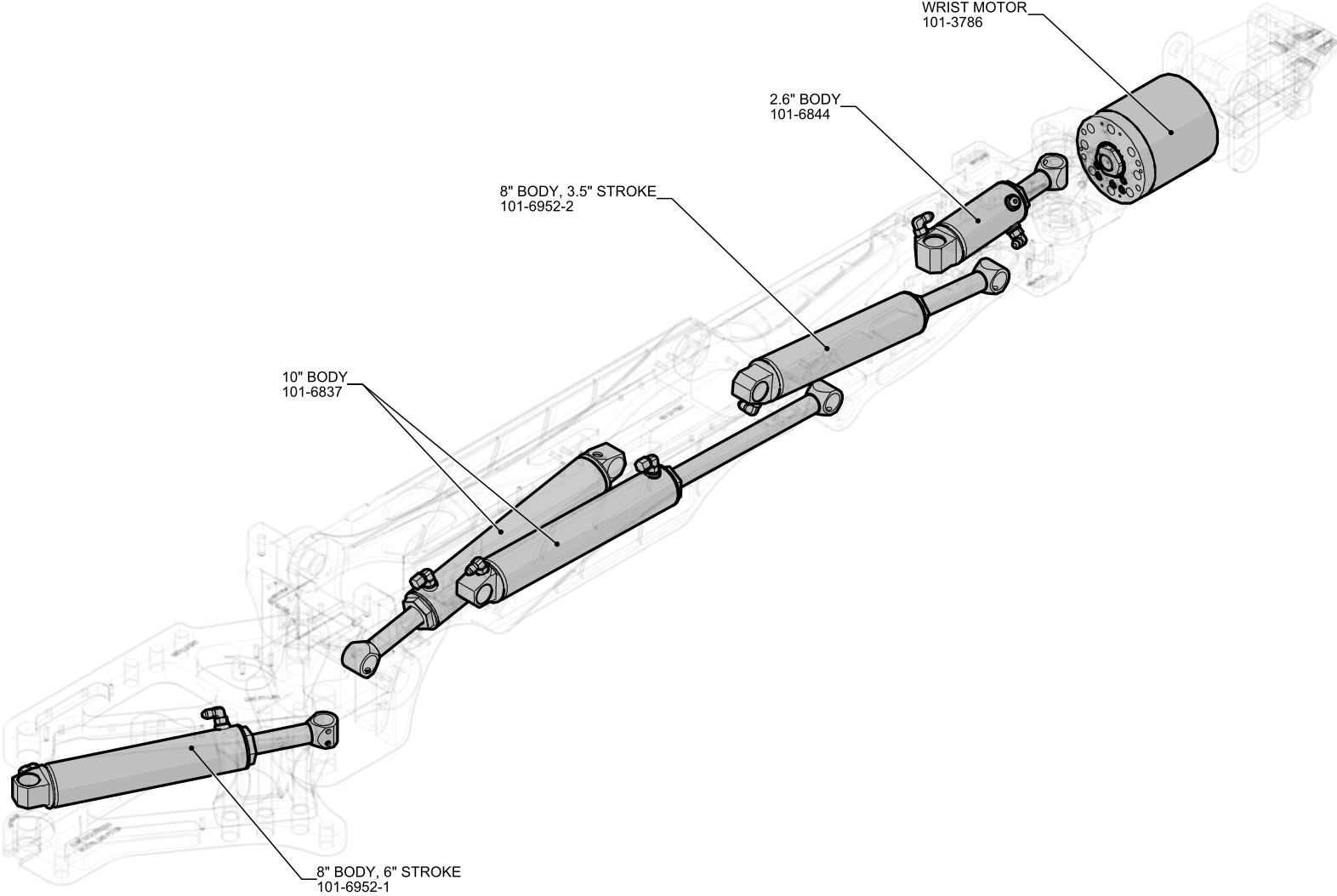

Anodes and Bump Stops

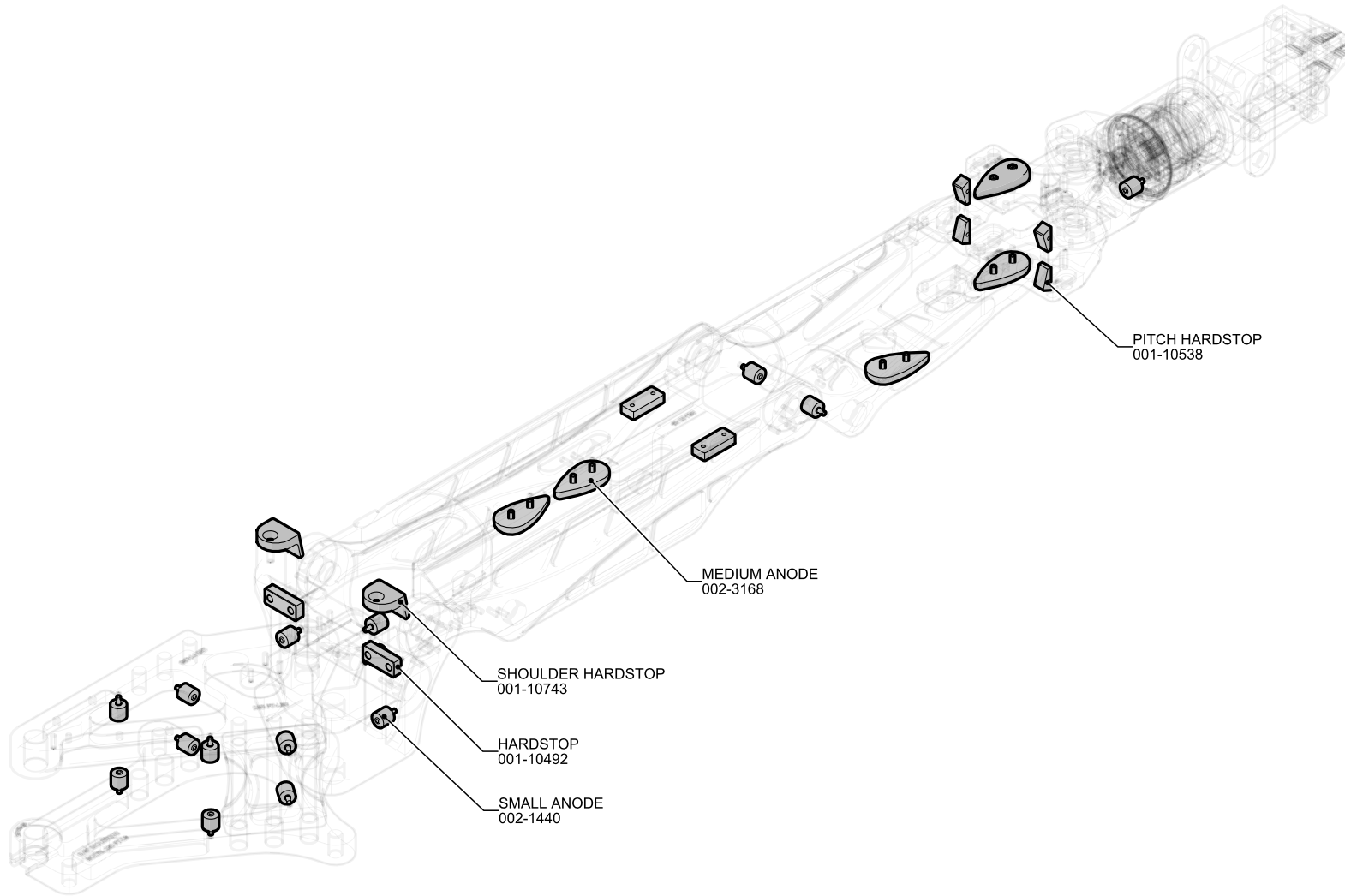

Bushings and Inserts

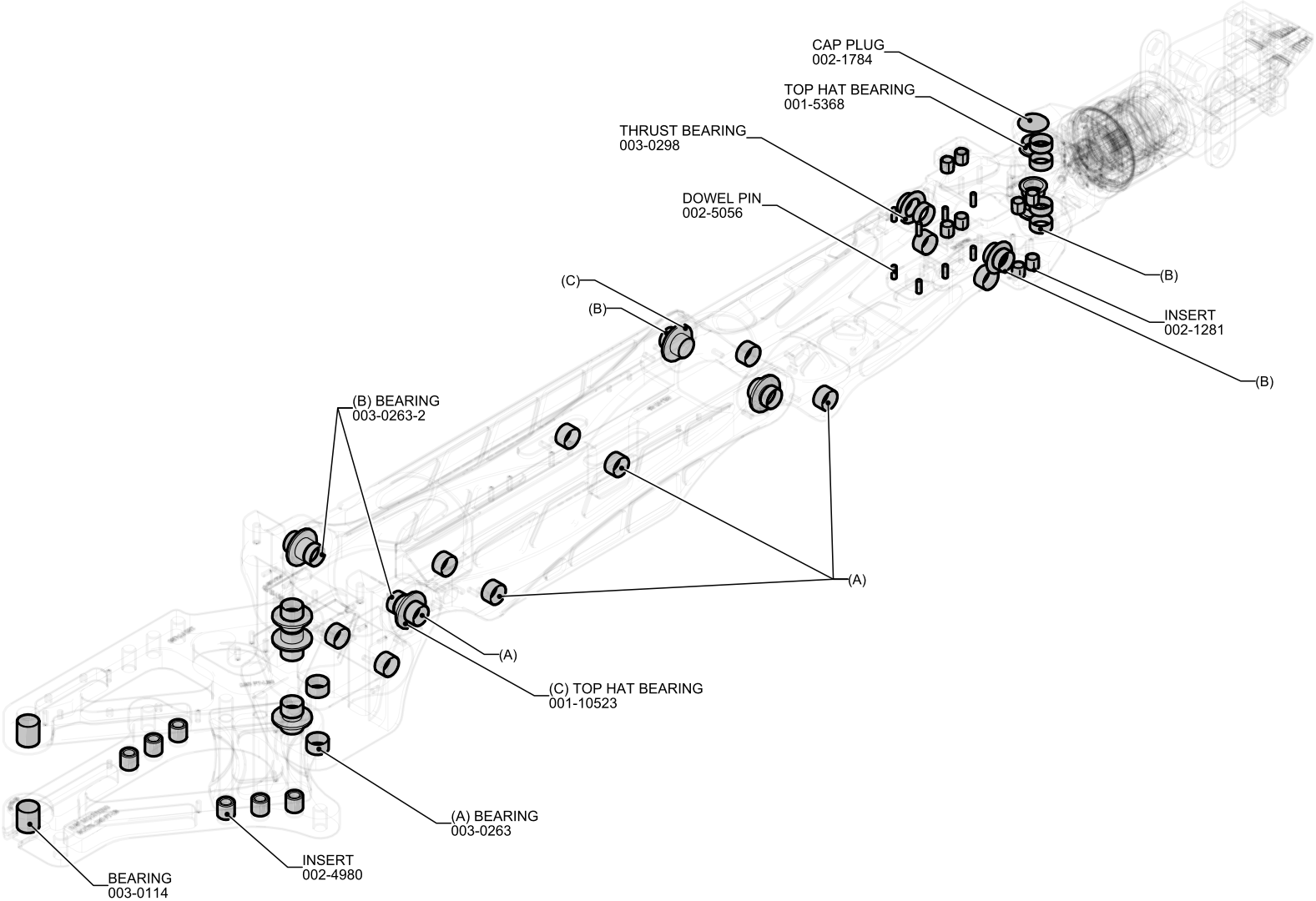

Sensor Covers

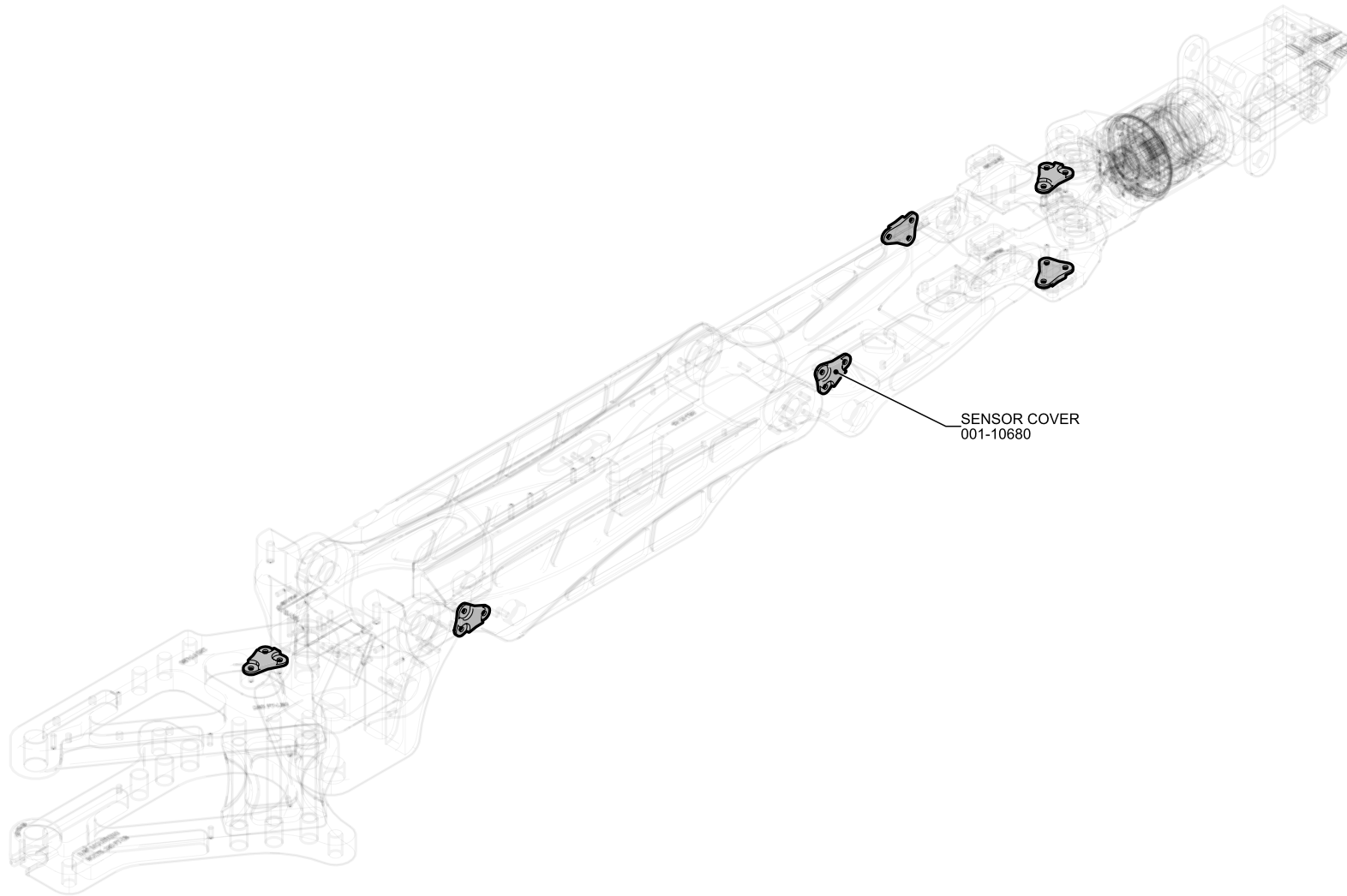

Pins and Spacers

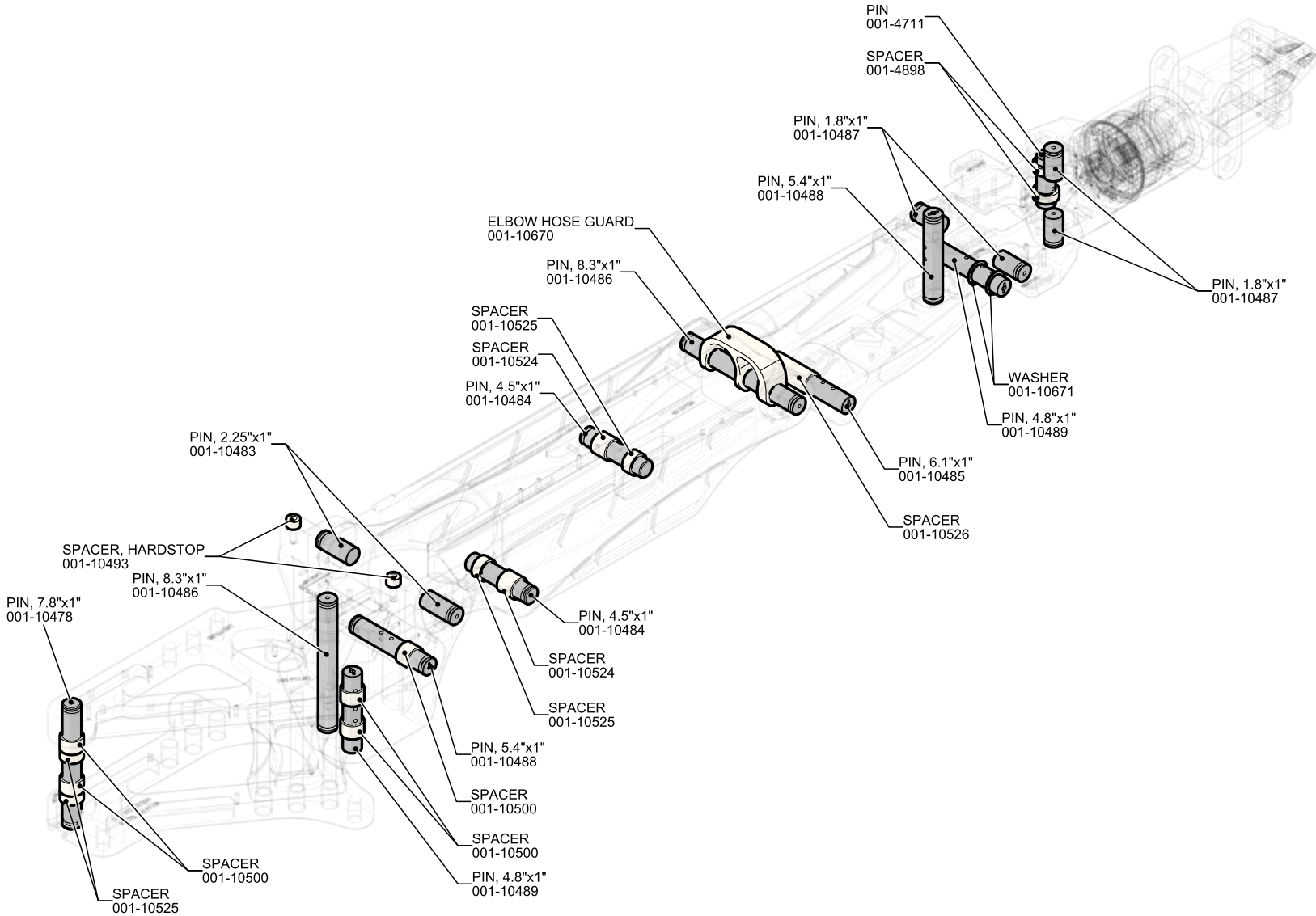

Major Structures

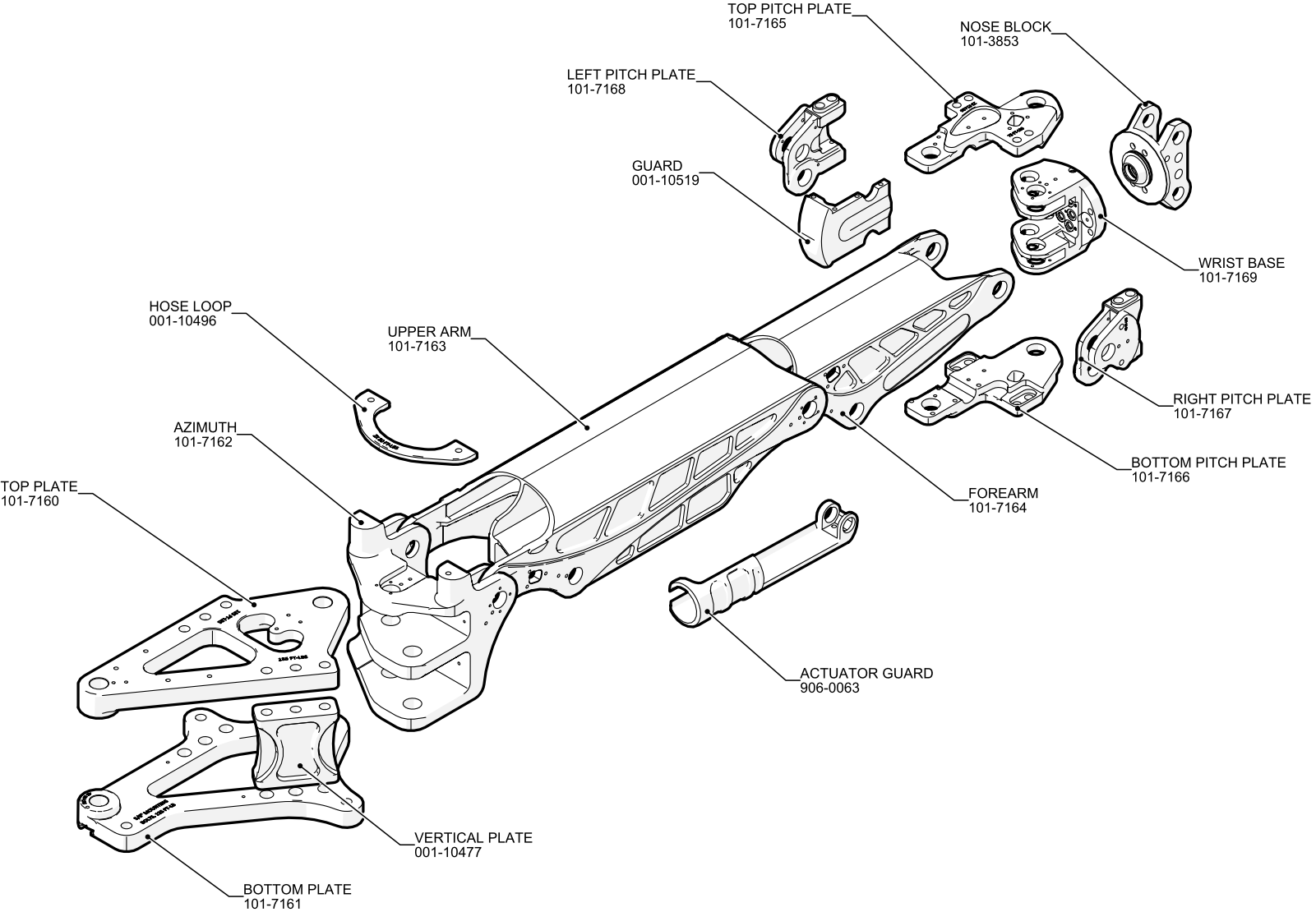

Linear Actuators

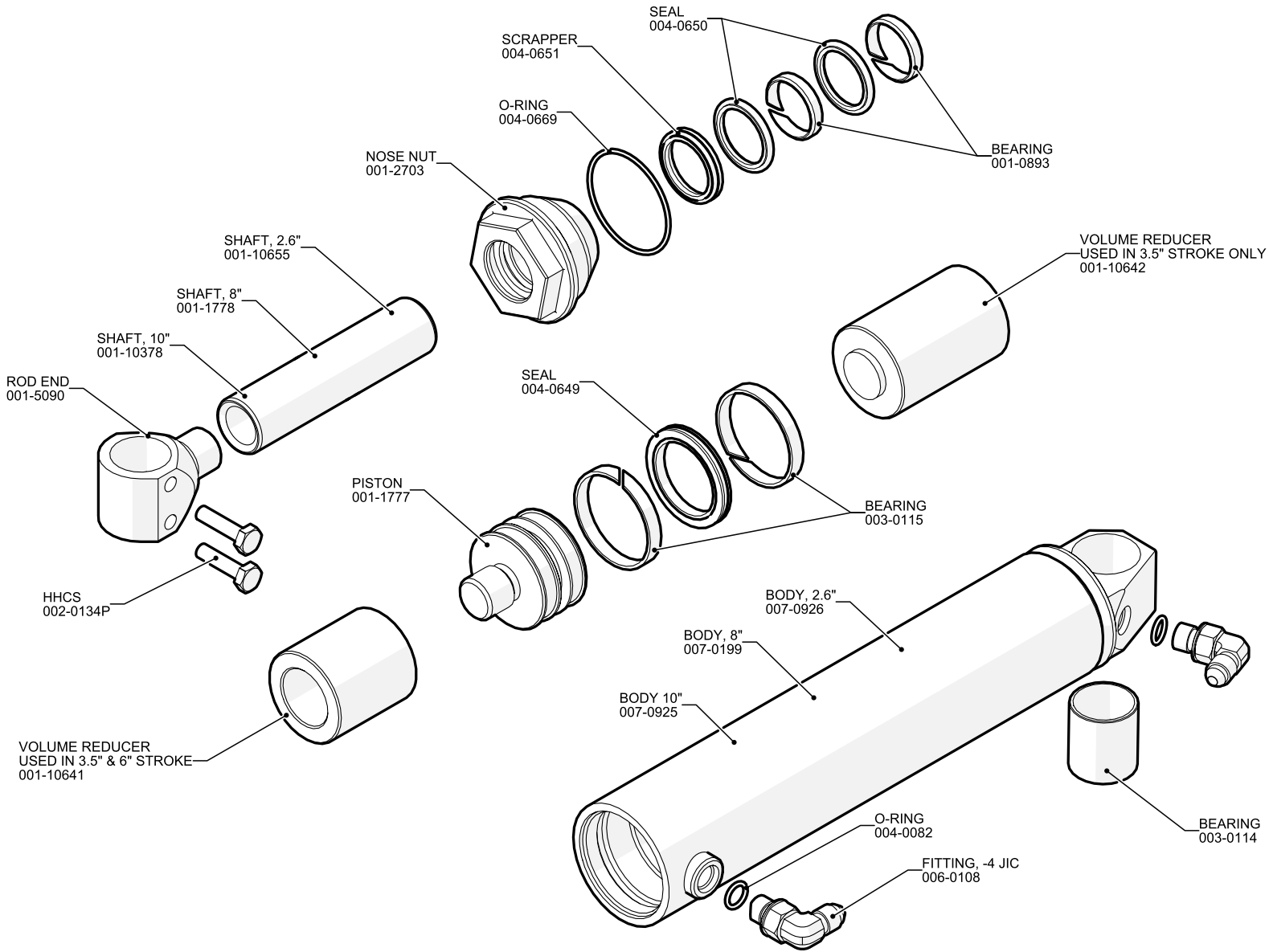

Wrist, 101-3786

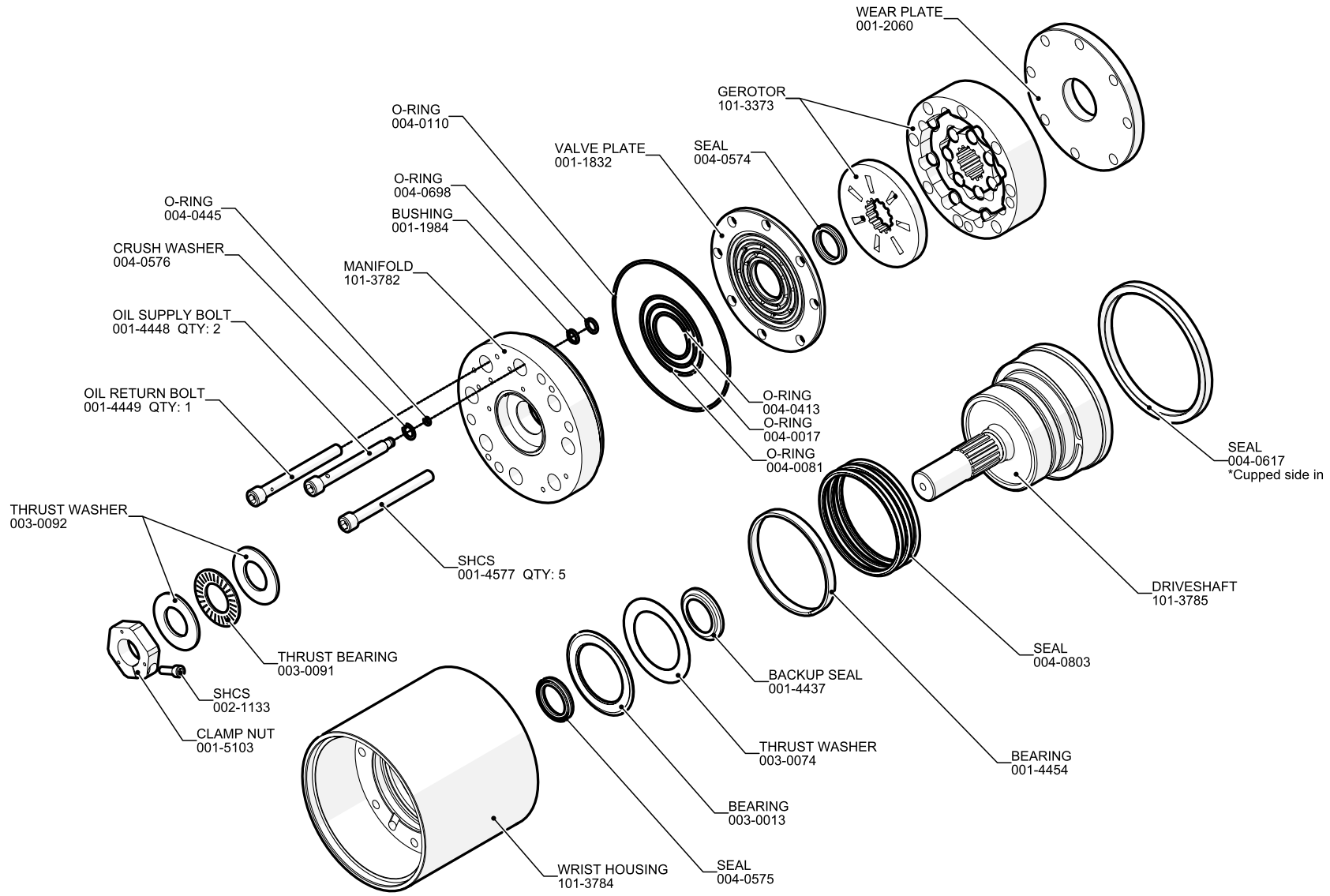

Jaw, 101-3299

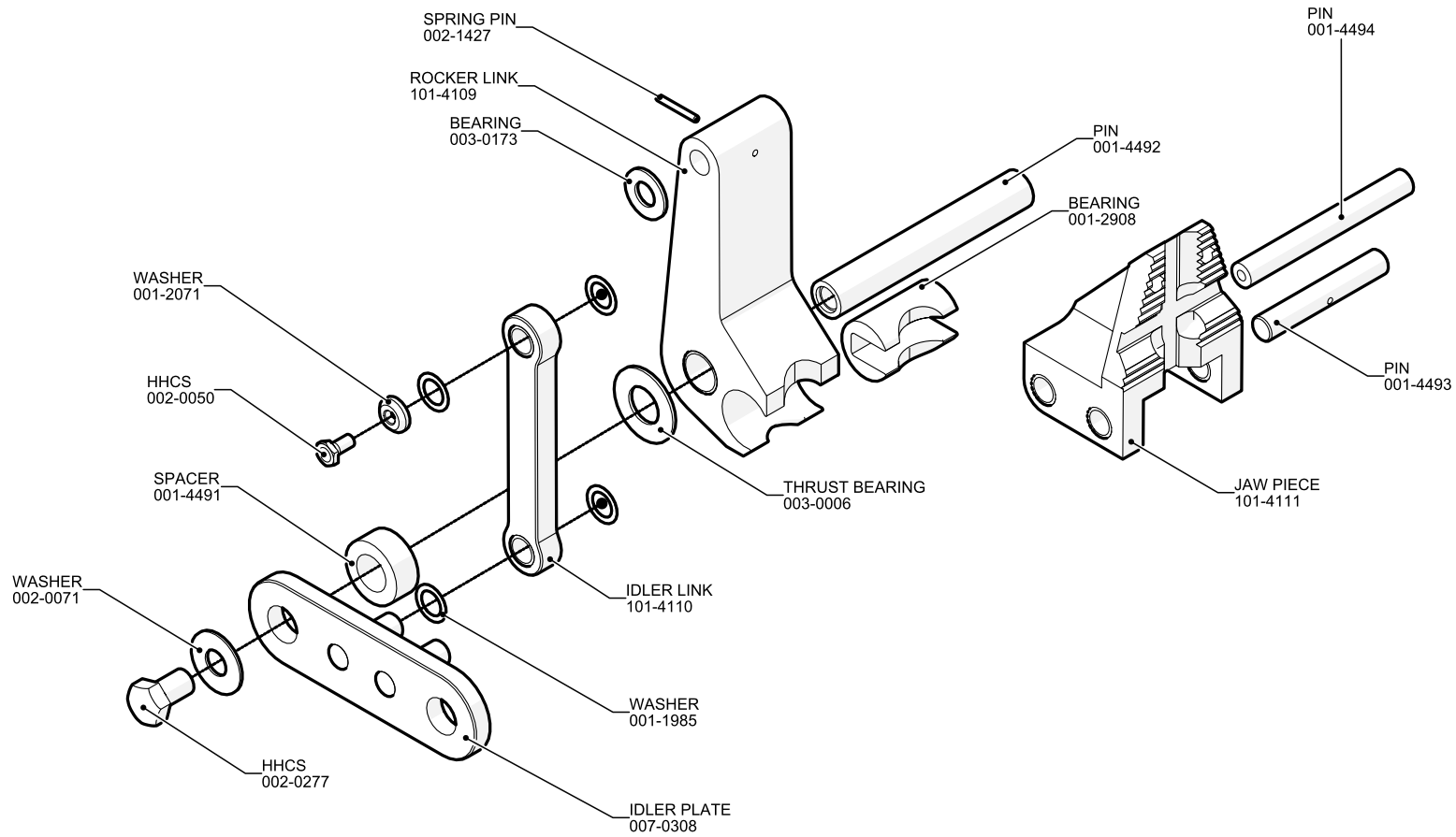

Jaws, 101-3569

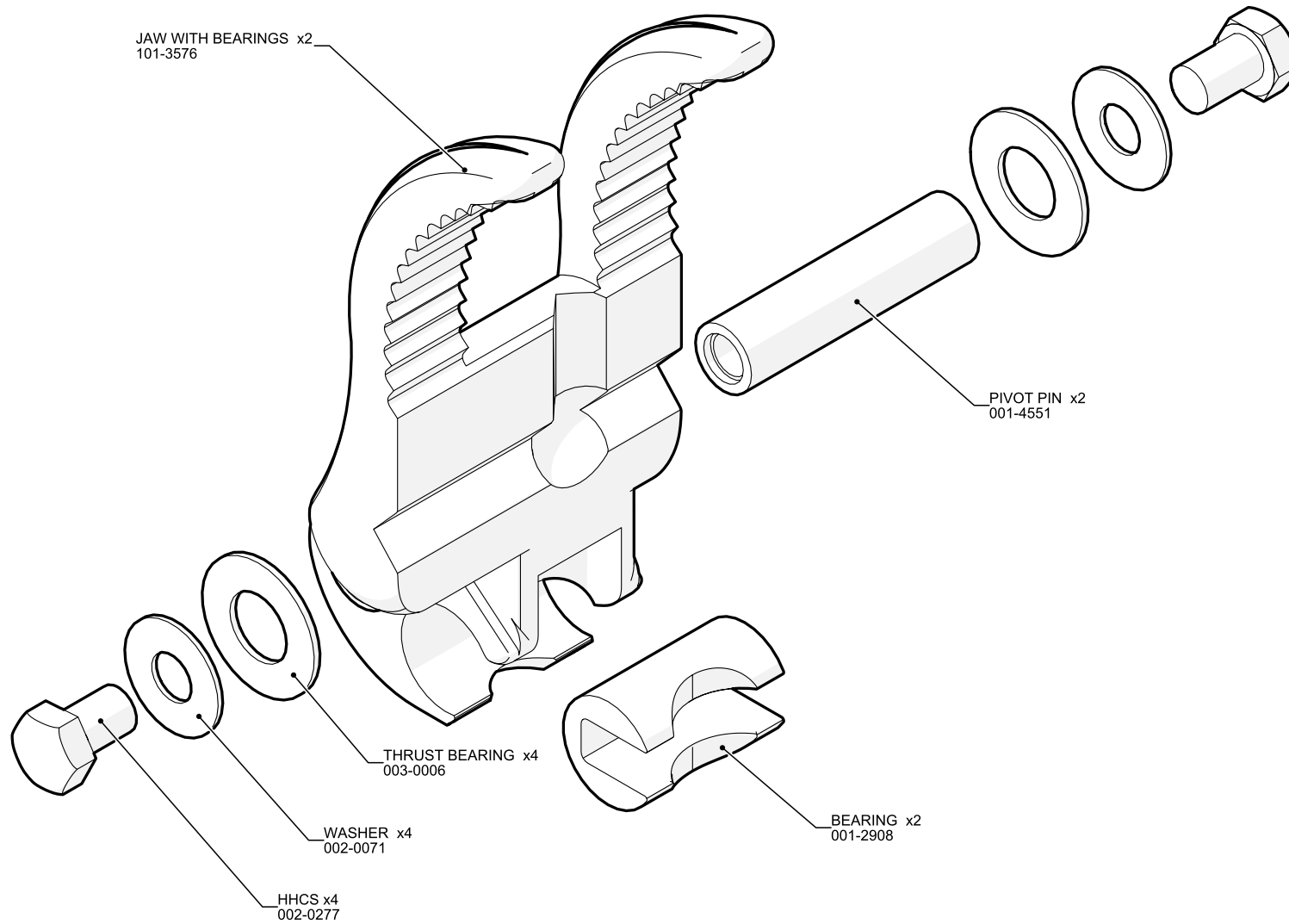

Noseblock, 101-3853

